

## N-Channel Enhancement Mode MOSFET

### Feature

- 40V/140A  
 $R_{DS(ON)} = 3.0$  @  $V_{GS} = 10V$   
 $R_{DS(ON)} = 4.0$  @  $V_{GS} = 4.5V$
- 100% Avalanche Tested
- 100% DVDS
- Reliable and Rugged
- Halogen Free and Green Devices Available  
 (RoHS Compliant)

### Pin Description

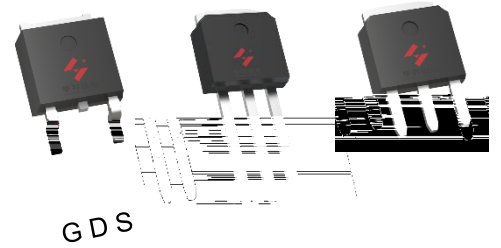

TO-252-2L      TO-251-3L      TO-251-3S

### Applications

- Load Switch
- Uninterrupted Power Supply
- Li-battery protection

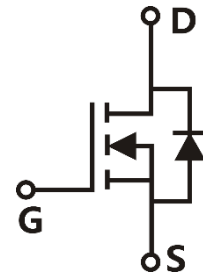

Single N-Channel MOSFET

### Ordering and Marking Information

<table style="width: 100%; border-collapse: collapse;"> <tr> <td style="text-align: center; width: 33%;"> <div style="background-color: black; width: 20px; height: 20px; margin: 0 auto;"></div>                 D                  HYG035N04                  XYMXXXXXX             </td> <td style="text-align: center; width: 33%;"> <div style="background-color: black; width: 20px; height: 20px; margin: 0 auto;"></div>                 U                  HYG035N04                  XYMXXXXXX             </td> <td style="text-align: center; width: 33%;"> <div style="background-color: black; width: 20px; height: 20px; margin: 0 auto;"></div>                 V                  HYG035N04                  XYMXXXXXX             </td> </tr> </table>	<div style="background-color: black; width: 20px; height: 20px; margin: 0 auto;"></div> D HYG035N04 XYMXXXXXX	<div style="background-color: black; width: 20px; height: 20px; margin: 0 auto;"></div> U HYG035N04 XYMXXXXXX	<div style="background-color: black; width: 20px; height: 20px; margin: 0 auto;"></div> V HYG035N04 XYMXXXXXX	Package Code D: TO-252-2L    U: TO-251-3L    V: TO-251-3S  Date Code XYMXXXXXX
<div style="background-color: black; width: 20px; height: 20px; margin: 0 auto;"></div> D HYG035N04 XYMXXXXXX	<div style="background-color: black; width: 20px; height: 20px; margin: 0 auto;"></div> U HYG035N04 XYMXXXXXX	<div style="background-color: black; width: 20px; height: 20px; margin: 0 auto;"></div> V HYG035N04 XYMXXXXXX		

Note: HUAYI halogen free products contain molding compounds/die attach materials and 100% matte tin plate Termination finish; which are fully compliant with RoHS. HUAYI halogen free products meet or exceed the halogen free requirements of IPC/JEDEC J-STD-020 for MSL classification at halogen free peak reflow temperature. HUAYI defines Green to mean halogen free (RoHS compliant) and halogen free (Br or Cl does not exceed 900ppm by weight in homogeneous material and total of Br and Cl does not exceed 1500ppm by weight).

HUAYI reserves the right to make changes, corrections, enhancements, modifications, and improvements to this product and/or to this document at any time without notice.

**HYG035N04LR1D/U/V**

## Electrical Characteristics (Cont.) (Tc =25°C Unless Otherwise Noted)

Symbol	Parameter	Test Conditions	HYG035N04LR1			Unit
			Min	Typ.	Max	

### Dynamic Characteristics

R<sub>G</sub>

**Typical Operating Characteristics**

**Figure 1: Power Dissipation**

**Figure 2: Drain Current**

**Figure 3: Safe Operation Area**

**Figure 4: Thermal Transient Impedance**

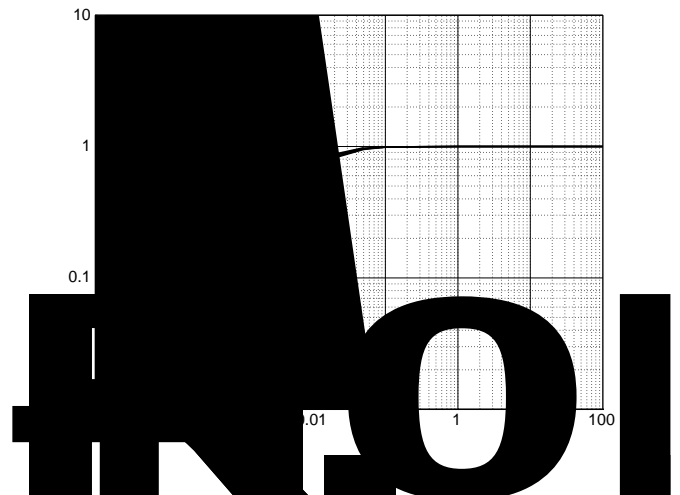
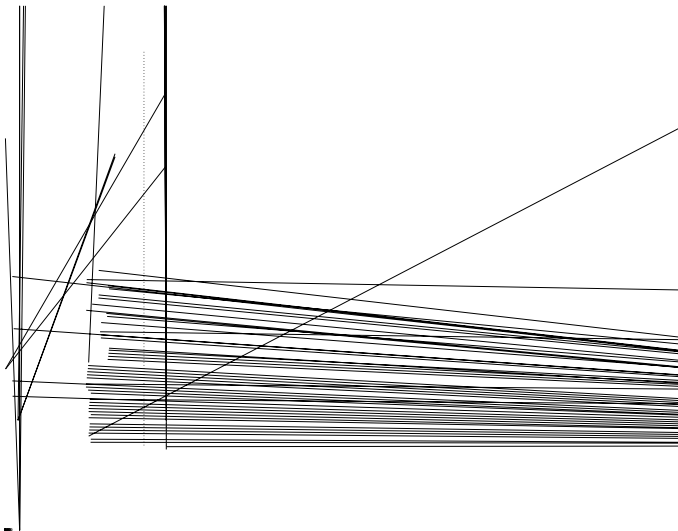

**Figure 5: Output Characteristics**

**Figure 6: Drain-Source On Resistance**

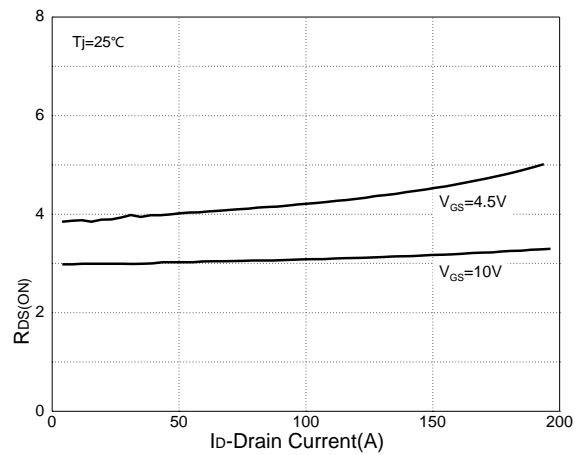
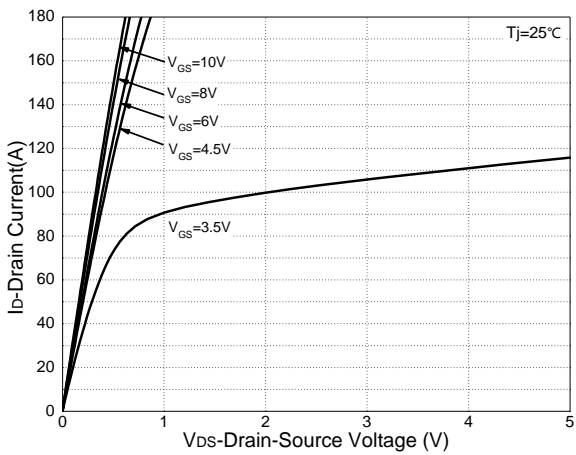

**Typical Operating Characteristics(Cont.)**

**Figure 7: On-Resistance vs. Temperature**

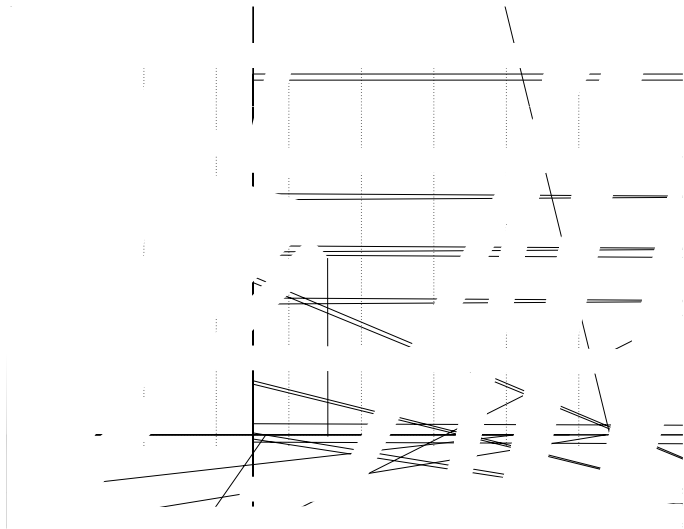

**Figure 8: Source-Drain Diode Forward**

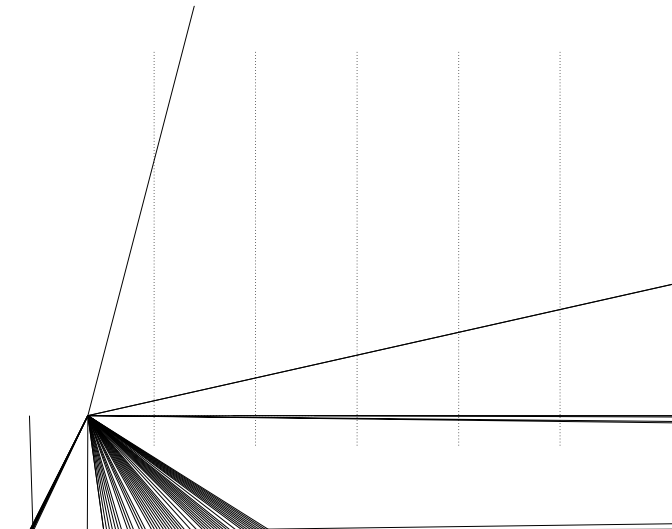

**Figure 9: Capacitance Characteristics**

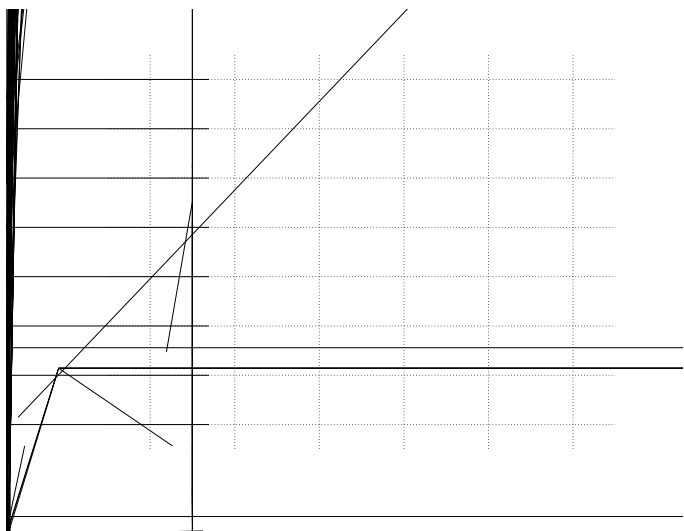

**Figure 10: Gate Charge Characteristics**

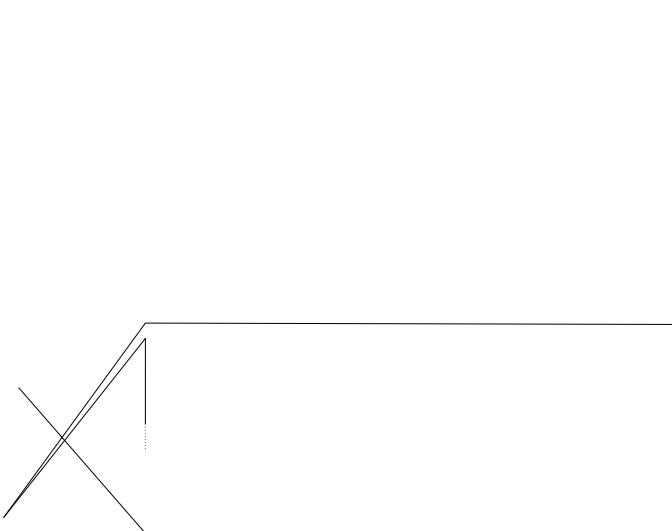

**Avalanche Test Circuit**

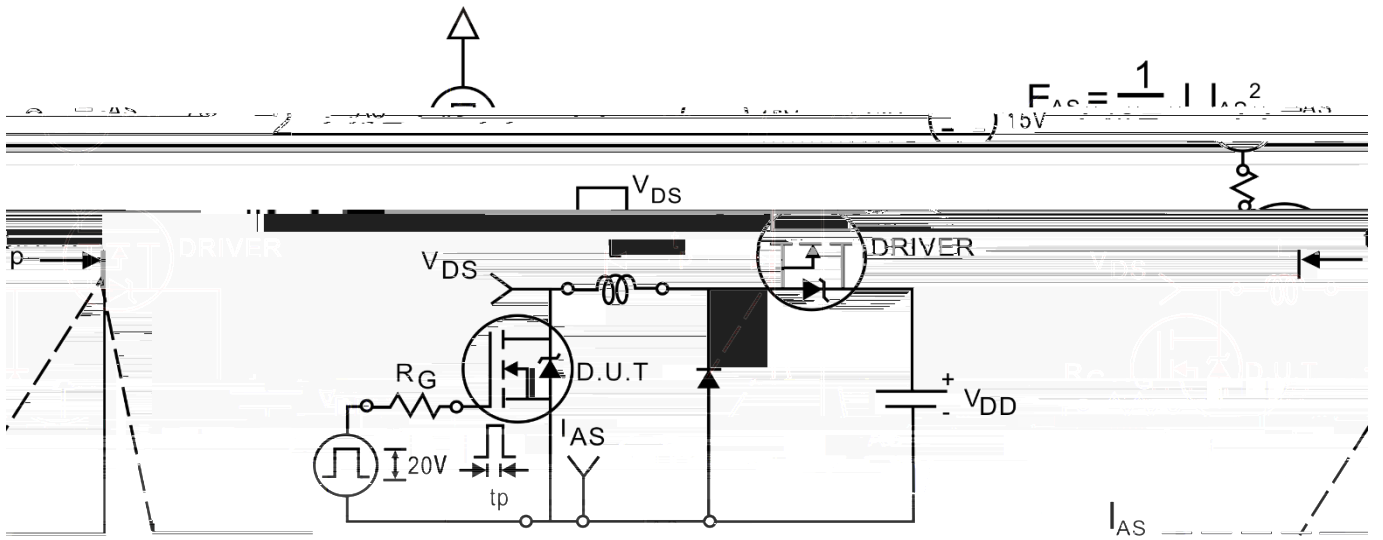

**Switching Time Test Circuit**

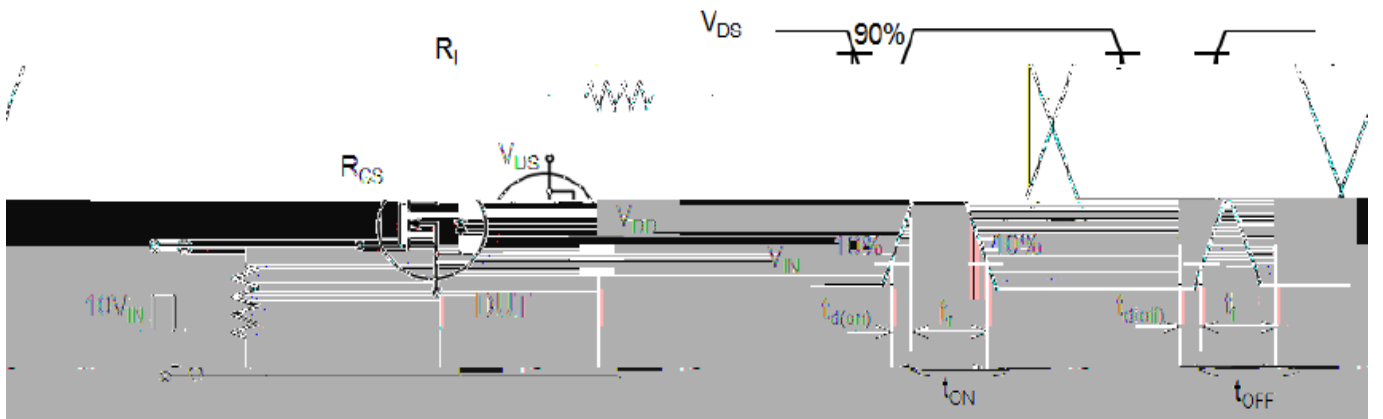

**Gate Charge Test Circuit**

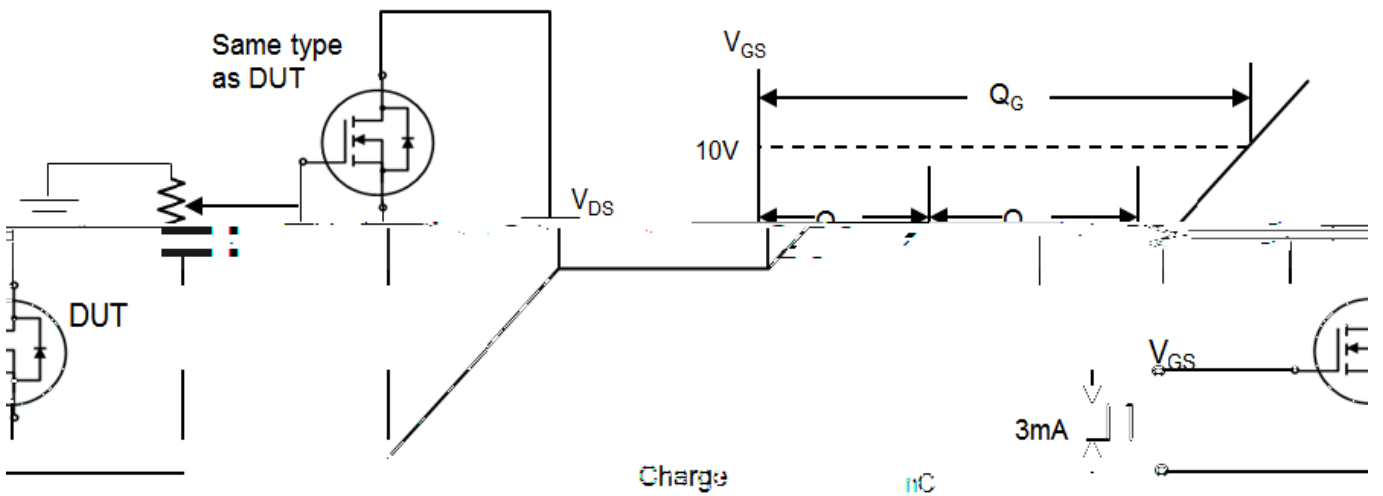

## Device Per Unit

Package Type	Unit	Quantity
TO-252-2L	Tube	75
TO-252-2L	Reel	2500
TO-251-3L	Tube	75
TO-251-3S	Tube	75

## Package Information

TO-252-2L

COMMON DIMENSIONS

TO-251-3L

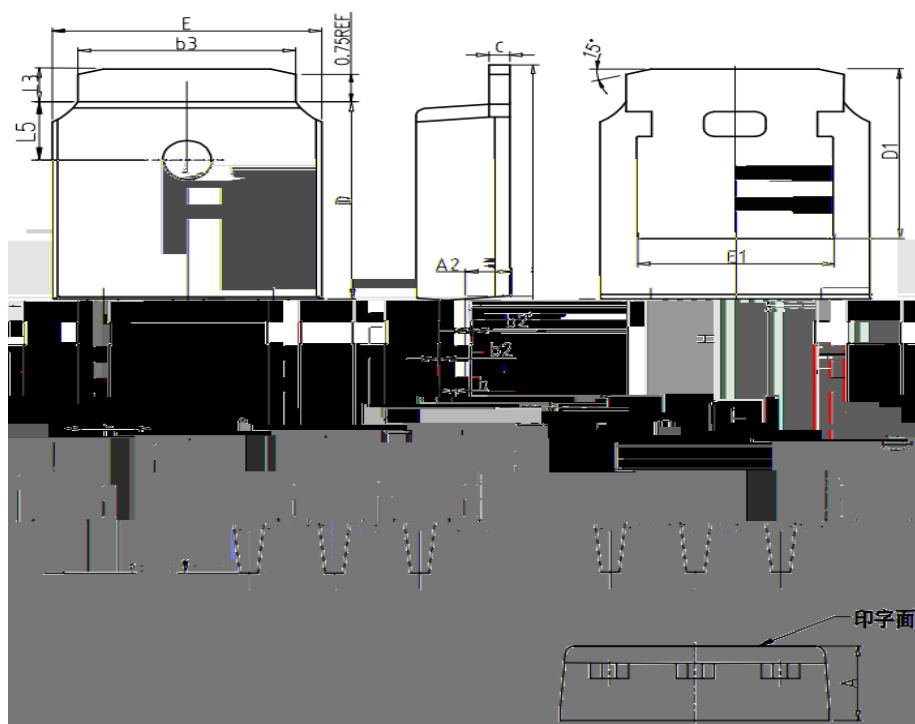

COMMON DIMENSIONS			
SYMBOL	mm		
	MIN	NOM	MAX
A	2.20	2.30	2.40
A2	0.97	1.07	1.17
b	0.68	0.78	0.90
b2	0.00	0.04	0.10
b2'	0.00	0.04	0.10
b3	5.20	5.33	5.50
c	0.43	0.53	0.63
D	5.98	6.10	6.22
D1	5.30REF		
E	6.40	6.60	6.80
E1	4.63	-	-
e	2.286BSC		
H	16.22	16.52	16.82
L1	9.15	9.40	9.65
L3	0.88	1.02	1.28
L5	1.65	1.80	1.95



TO-251-3S

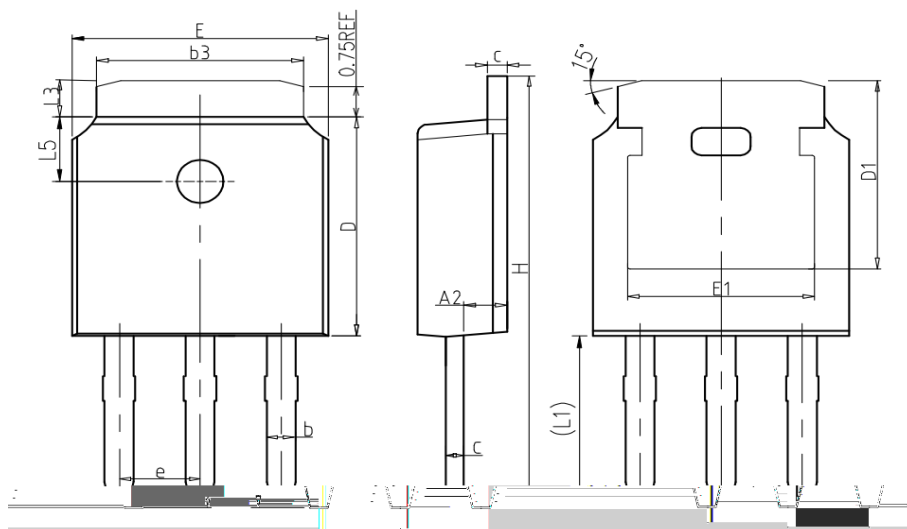

印字面

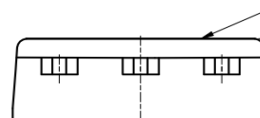

COMMON DIMENSIONS			
SYMBOL	mm		
	MIN	NOM	MAX
A	2.20	2.30	2.40
A2	0.97	1.07	1.17
b	0.68	0.78	0.90
b3	5.20	5.33	5.50
c	0.43	0.53	0.63
D	5.98	6.10	6.22
D1	5.30REF		
E	6.40	6.60	6.80
E1	4.63	-	-
e	2.286BSC		
H	10.00	11.22	11.44
L1	3.90	4.10	4.30
L3	0.88	1.02	1.28
L5	1.65	1.80	1.95

## Classification Profile

## Classification Reflow Profiles

Profile Feature	Sn-Pb Eutectic Assembly	Pb-Free Assembly
<b>Preheat &amp; Soak</b>		
Temperature min ( $T_{smin}$ )	100 °C	150 °C
Temperature max ( $T_{smax}$ )	150 °C	200 °C
Time ( $T_{smin}$ to $T_{smax}$ ) ( $t_s$ )	60-120 seconds	60-120 seconds
Average ramp-up rate ( $T_{smax}$ to $T_P$ )	3 °C/second max.	3°C/second max.
Liquidous temperature ( $T_L$ )	183 °C	217 °C
Time at liquidous ( $t_L$ )	60-150 seconds	60-150 seconds
Peak package body Temperature ( $T_P$ )*		

Table 1. SnPb Eutectic Process Classification Temperatures (Tc)

Package Thickness	Volume mm <350	Volume mm 350
2.5 mm	235 °C	220 °C
	220 °C	220 °C

Table 2. Pb-free Process Classification Temperatures (Tc)

Package Thickness	Volume mm <350	Volume mm 350-2000	Volume mm 2000
<1.6 mm	260 °C	260 °C	260 °C
1.6 mm 2.5 mm	260 °C	250 °C	245 °C
2.5 mm	250 °C	245 °C	245 °C

## Reliability Test Program

Test item	Method	Description
SOLDERABILITY	JESD-22, B102	5 Sec, 245°C
HTRB	JESD-22, A108	168/500 Hrs, Bias @ 150°C
HTGB	JESD-22, A108	168 /500 Hrs, V <sub>gs</sub> 100% @ 150°C
PCT	JESD-22, A102	96 Hrs, 100%RH, 2atm, 121°C
TCT	JESD-22, A104	250/500 Cycles, -55°C~150°C

## Customer Service

Worldwide Sales and Service: [sales@hymexa.com](mailto:sales@hymexa.com)

Technical ID 31-BDXp5(cpS)5(ort:ET EMC /P <</MCID 125/Lang (en-US)-BDC BT1 0 0 1 42.6 ang79.44 Tm[T]93(ecET EMC