

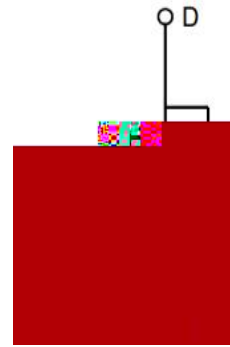

•

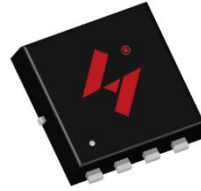

()			
	()		
θ			
θ			

()

()				
()				

()

()						
()						

%

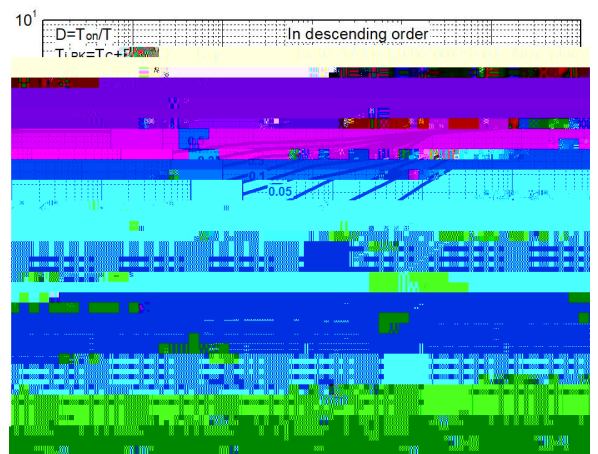
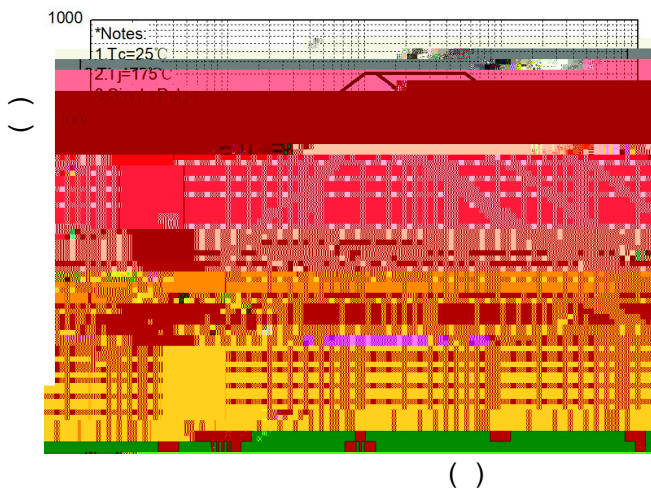
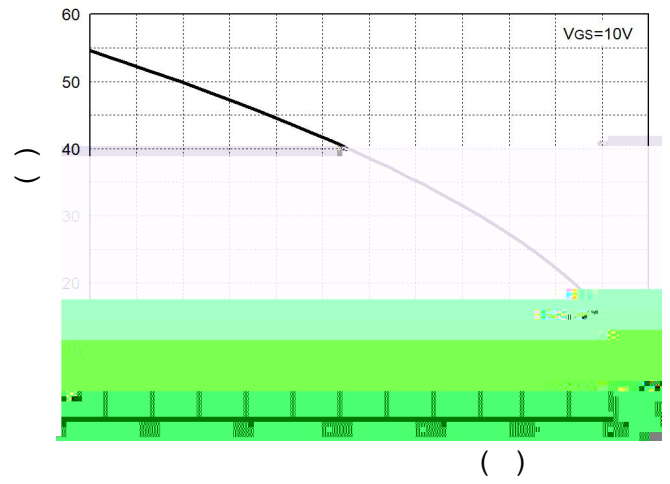
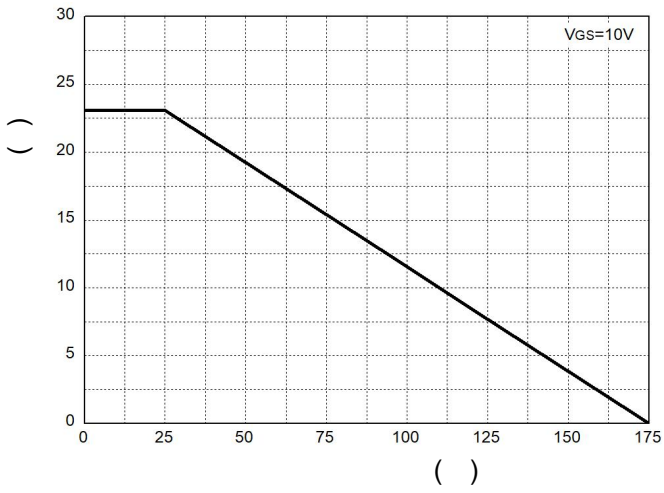

Maximum Effective Transient Thermal Impedance, Junction-to-Case

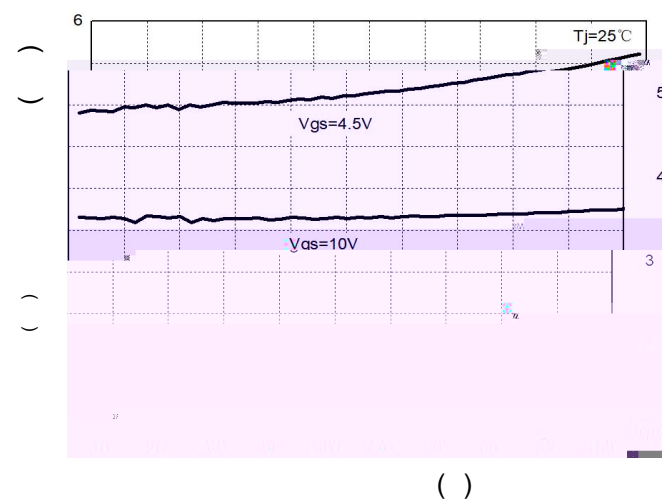
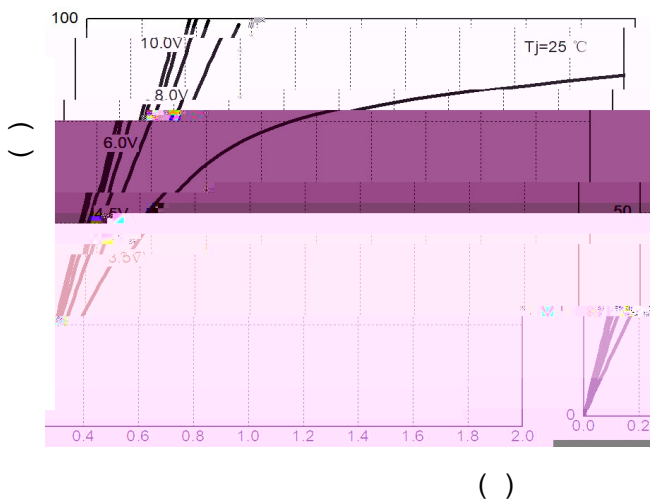

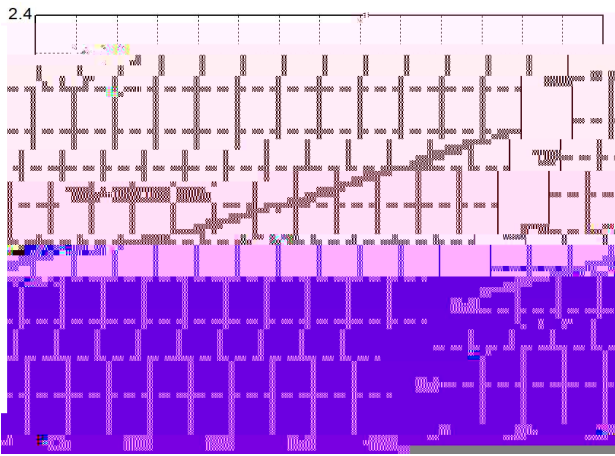

()

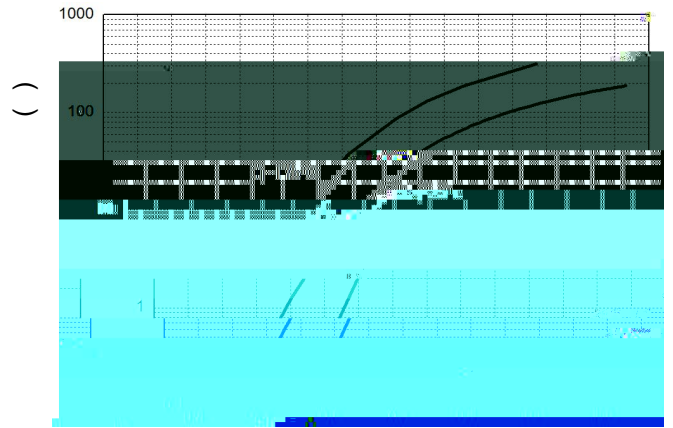

()

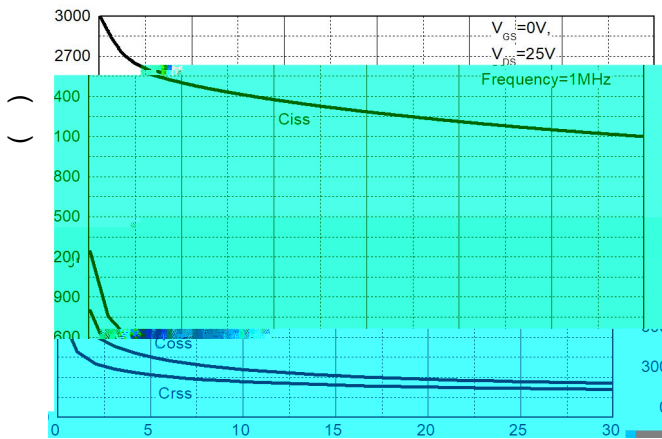

()

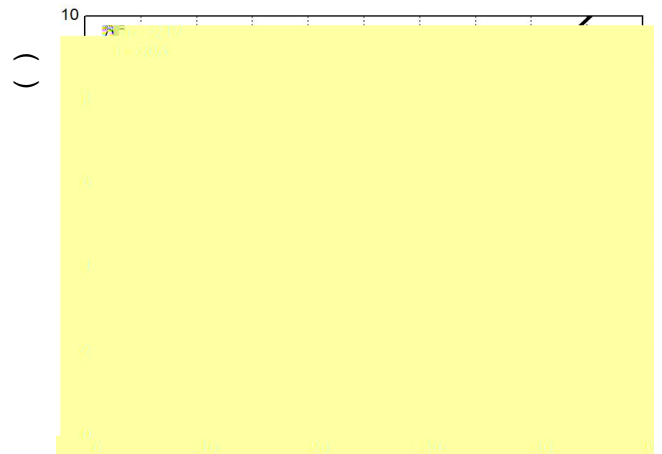

()

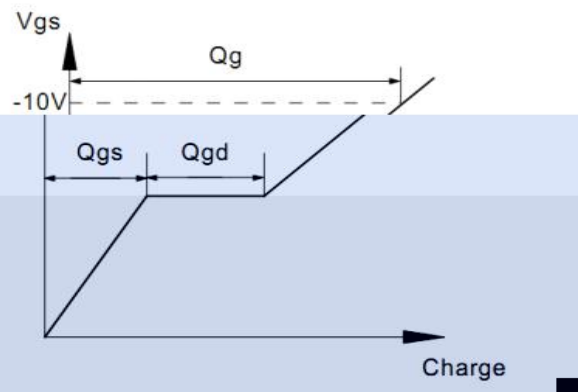
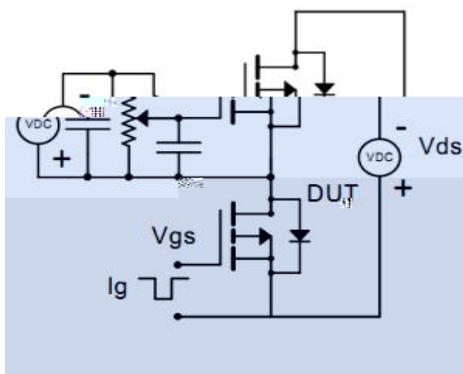
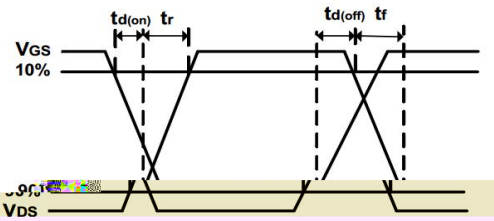
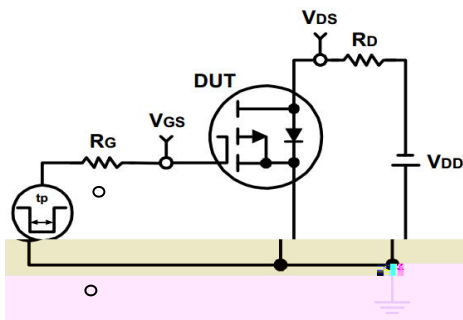
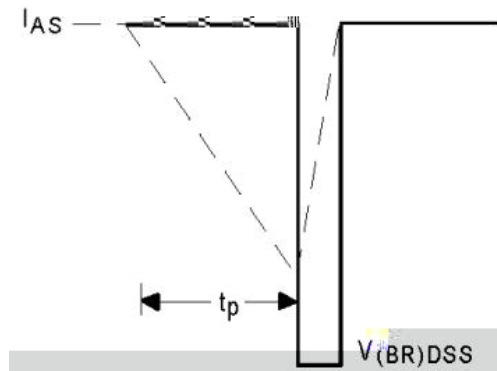
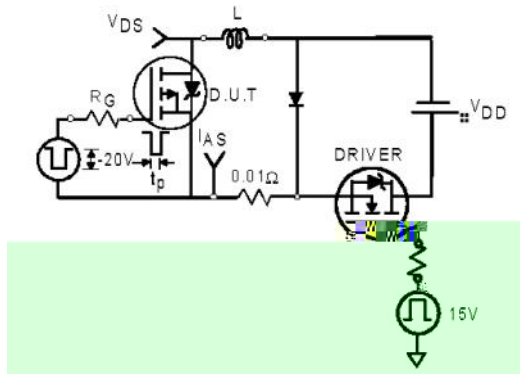

()		

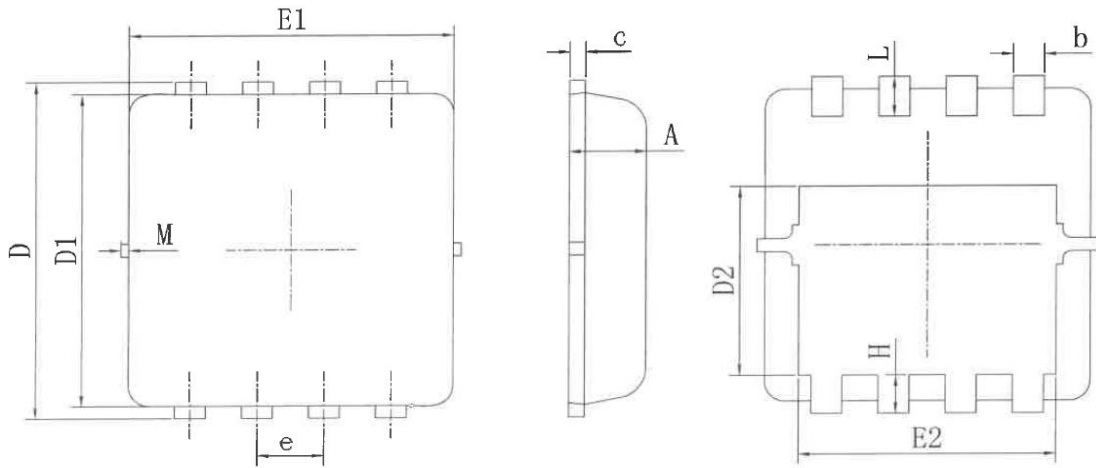

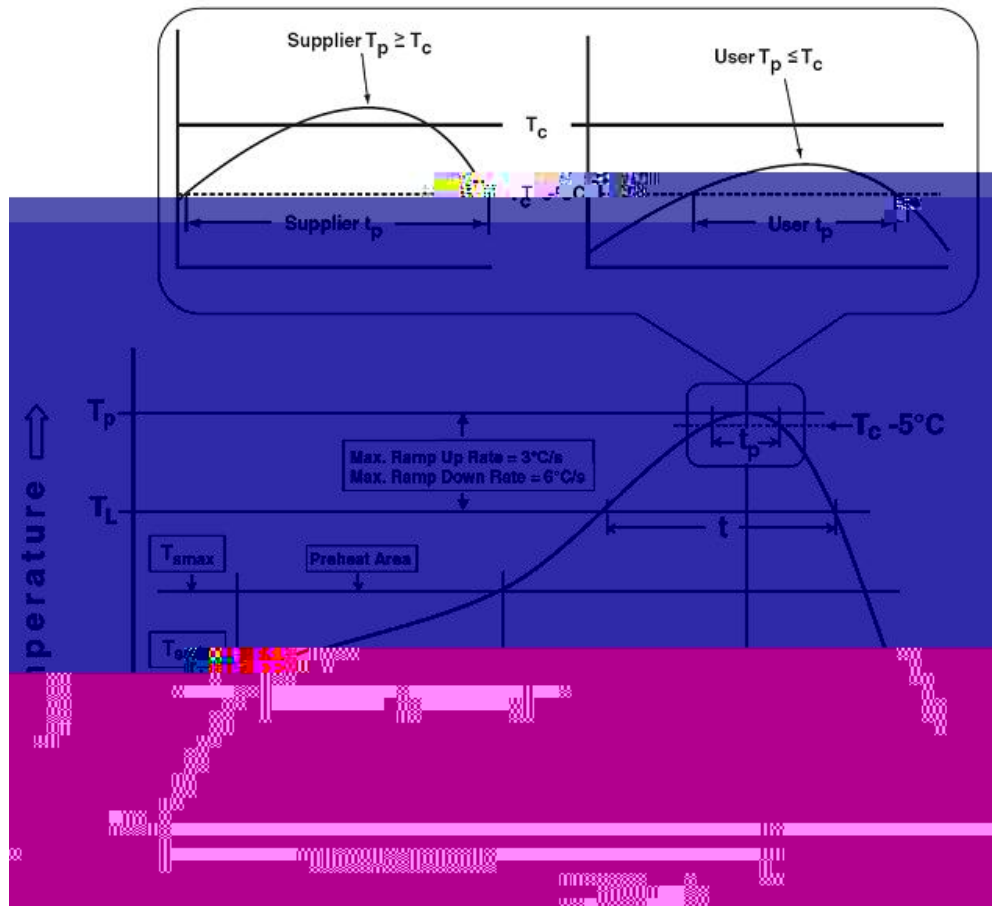

()		
()		
() ()		
()		
() ()		
()		
()		
() ()		
() ()		
()		
() ()		
()		
() ()		
()		
() ()		

()

()

		%
		%
		%

()
()