

Single N-Channel Enhancement Mode MOSFET

Feature

- 30V/80A
- | | |
|--------------|-------------------|
| $R_{DS(ON)}$ | @ $V_{GS} = 10V$ |
| $R_{DS(ON)}$ | @ $V_{GS} = 4.5V$ |
- 100% Avalanche Tested
- Reliable and Rugged
- Halogen- Free Devices Available

Pin Description

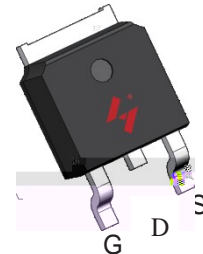

Applications

- Load Switch
- Li-battery protection

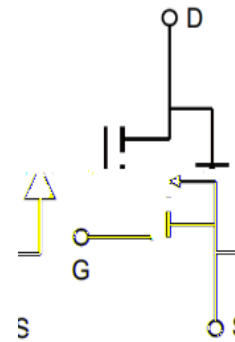

Single N-Channel MOSFET

Ordering and Marking Information

 D G045N03 XYMXXXXXX	<p>Package Code D: TO-252-2L</p> <p>Date Code XYMXXXXXX</p>
--	---

Note: HUAYI lead-free products contain molding compounds/die attach materials and 100% matte tin plate Termination finish; which are fully compliant with RoHS. HUAYI lead-free products meet or exceed the lead-free requirements of IPC/JEDEC J-STD-020 for MSL classification at lead-free peak reflow temperature. HUAYI defines “Green” to mean lead-free (RoHS compliant) and halogen free (Br or Cl does not exceed 900ppm by weight in homogeneous material and total of Br and Cl does not exceed 1500ppm by weight).

HUAYI reserves the right to make changes, corrections, enhancements, modifications, and improvements to this product and/or to this document at any time without notice.

Absolute Maximum Ratings

Symbol	Parameter	Rating	Unit
Common Ratings (T _c =25 Unless Otherwise Noted)			
V _{DSS}	Drain-Source Voltage	30	V
V _{GSS}	Gate-Source Voltage	20	V
T _J	Junction Temperature Range	-55 to 175	
T _{STG}	Storage Temperature Range	-55 to 175	
I _S	Source Current-Continuous(Body Diode)	T _c =25	A
Mounted on Large Heat Sink			
I _{DM}	Pulsed Drain Current *	T _c =25	290 A
I _D	Continuous Drain Current	T _c =25	80 A
		T _c =100	56 A
P _D	Maximum Power Dissipation	T _c =25	57 W
		T _c =100	28 W

R_{JC}

Electrical Characteristics (Cont.) (Tc =25 Unless Otherwise Noted)

Symbol	Parameter	Test Conditions	HYG045N03LA1			Unit	
			Min	Typ.	Max		
Dynamic Characteristics							
R _G	Gate Resistance	V _{GS} =0V, V _{DS} =0V, F=1MHz	-	10	-		
C _{iss}	Input Capacitance	V _{GS} =0V, V _{DS} =25V, Frequency=1.0MHz	-	2156	-	pF	
C _{oss}	Output Capacitance		-	270	-		
C _{rss}	Reverse Transfer Capacitance		-	221	-		
t _{d(ON)}	Turn-on Delay Time	V _{DD} =15V, R _G =4 I _{DS} =20A, V _{GS} =10V	-	7	-	ns	
T _r	Turn-on Rise Time		-	61	-		
t _{d(OFF)}	Turn-off Delay Time		-	101	-		
T _f	Turn-off Fall Time		-	66	-		
Gate Charge Characteristics							
Q _g	Total Gate Charge V _{GS} =4.5V)	V _{DS} =24V, V _{GS} =10V, I _D =20A	-	47	-	nC	
Q _g			-	26	-		
Q _{gs}			Gate-Source Charge	-	7		-
Q _{gd}			Gate-Drain Charge	-			

Z jc Normalized Tr

$I_{S-Source}$ Current (A)

V_{GS-}

HYG045N03LA1D

Avalanche Test Circuit

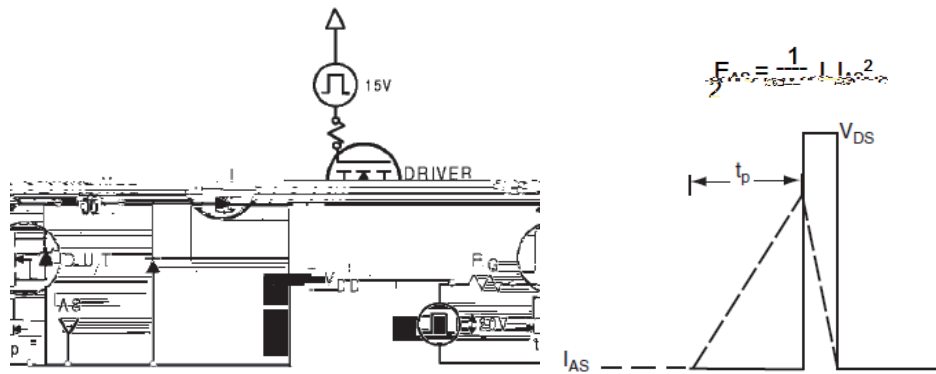

Switching Time Test Circuit

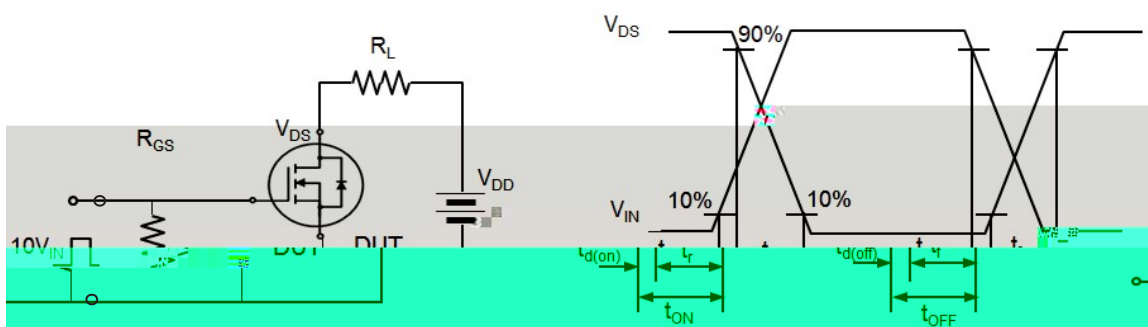

Gate Charge Test Circuit

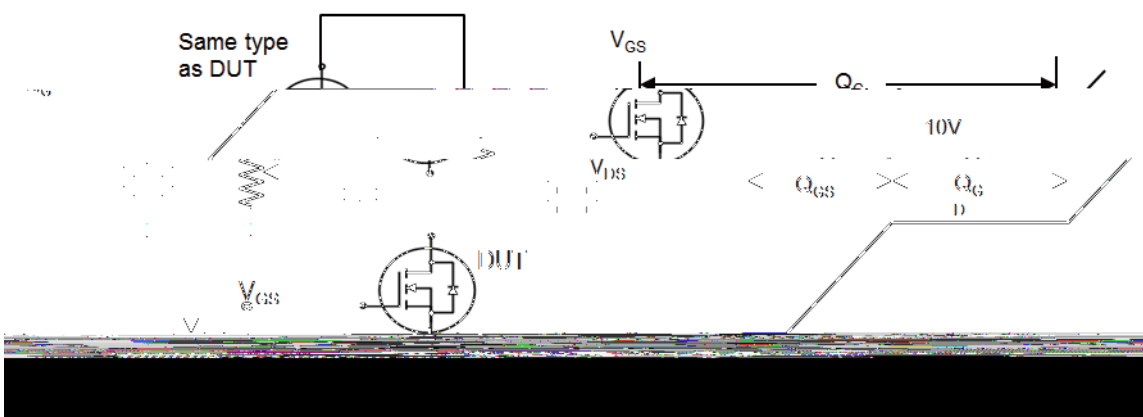

Table 1. SnPb Eutectic Process – Classification Temperatures (Tc)

Package Thickness	Volume mm <350	Volume mm 350
2.5 mm	235	220
mm	220	220

Table 2. Pb-free Process – Classification Temperatures (Tc)

Package Thickness	Volume mm <350	Volume mm 350-2000	Volume mm 2000
<1.6 mm	260	260	260
1.6 mm –			