

0 0 1

--

•

•

•

•

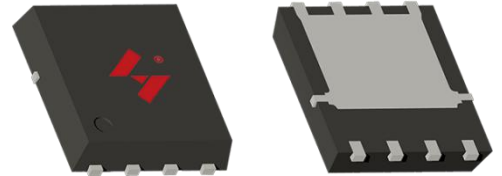

•

•

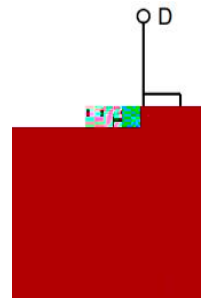

	
---	--





0 0 1

1

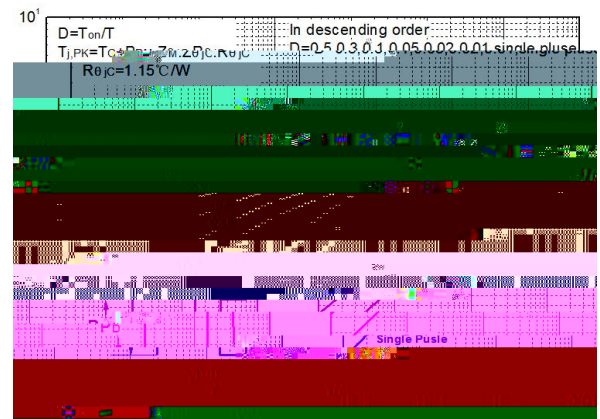
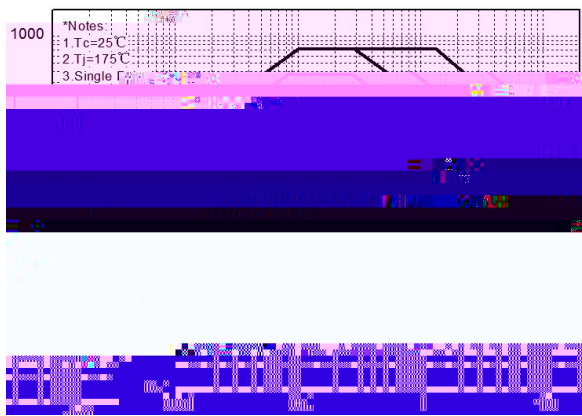
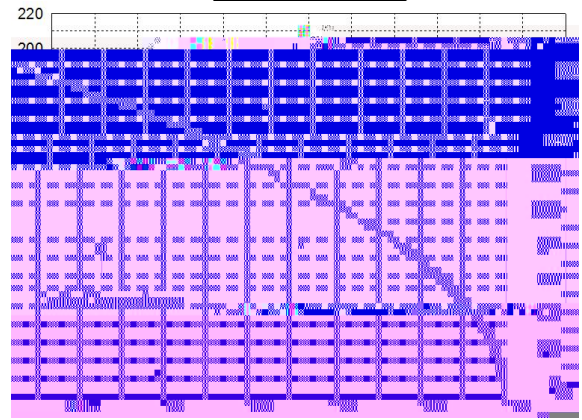
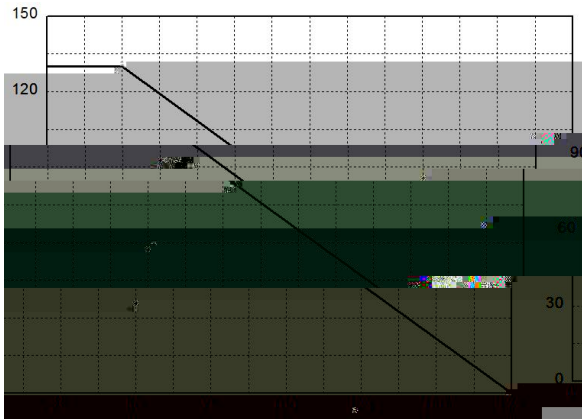

Maximum Effective Transient Thermal Impedance Junction Case

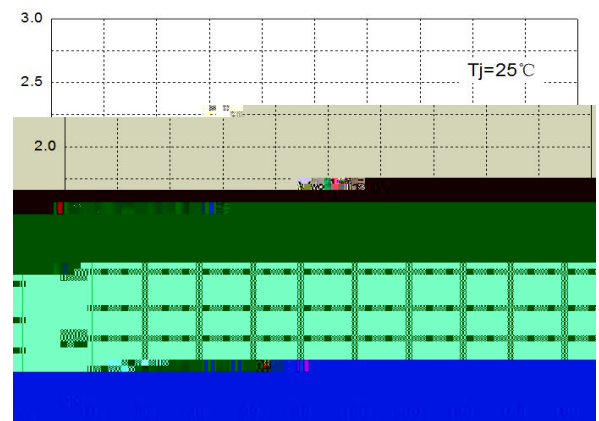
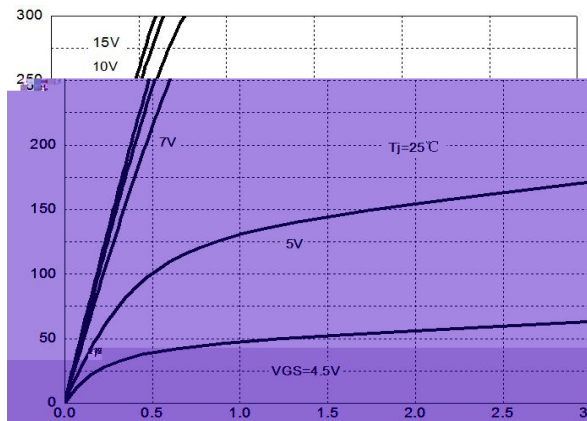

0 0 1

( . )

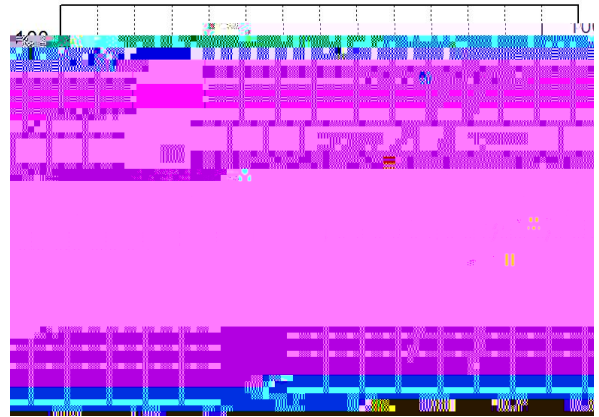
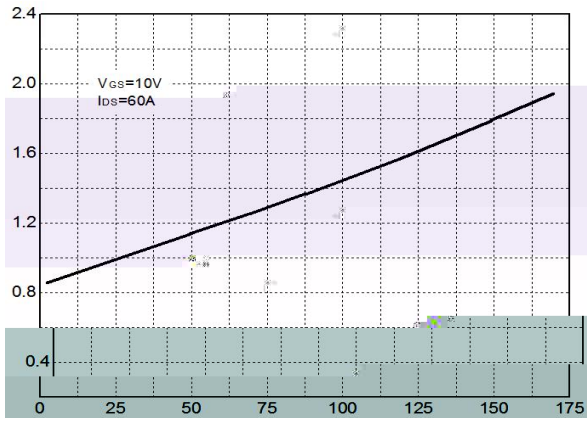

10

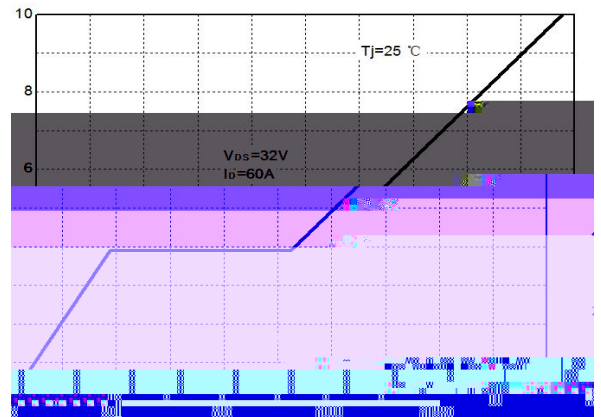
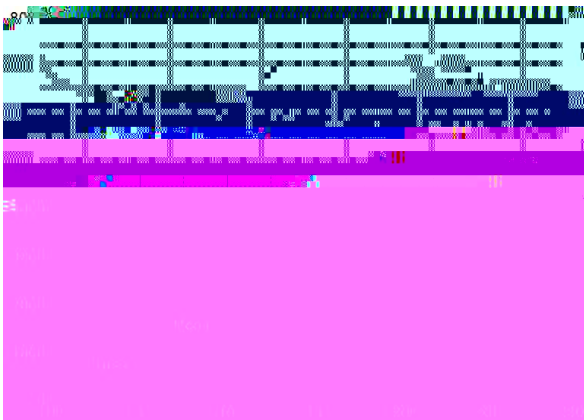

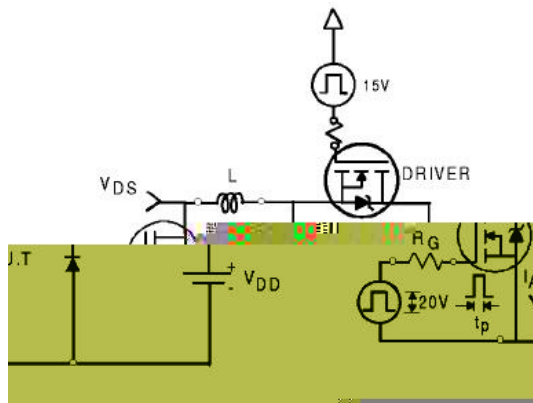

$$E_{AS} = \frac{1}{2} L I_{AS}^2$$

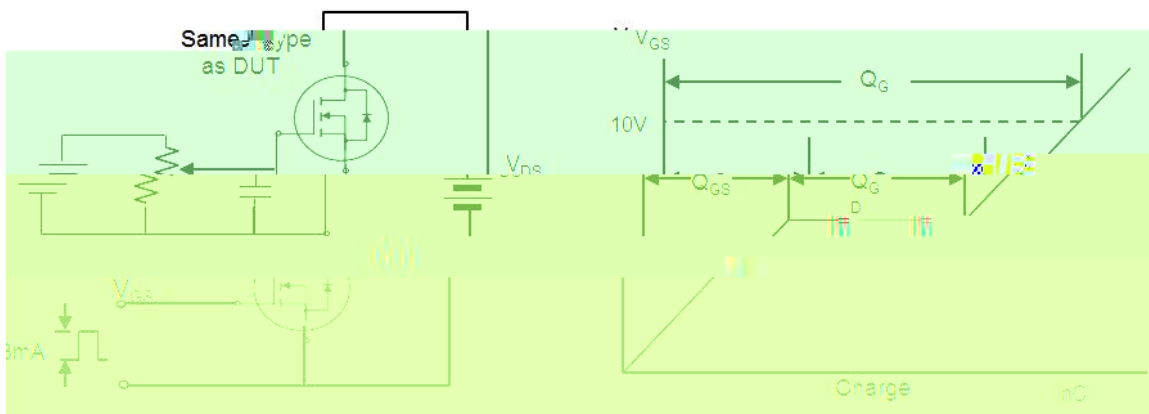
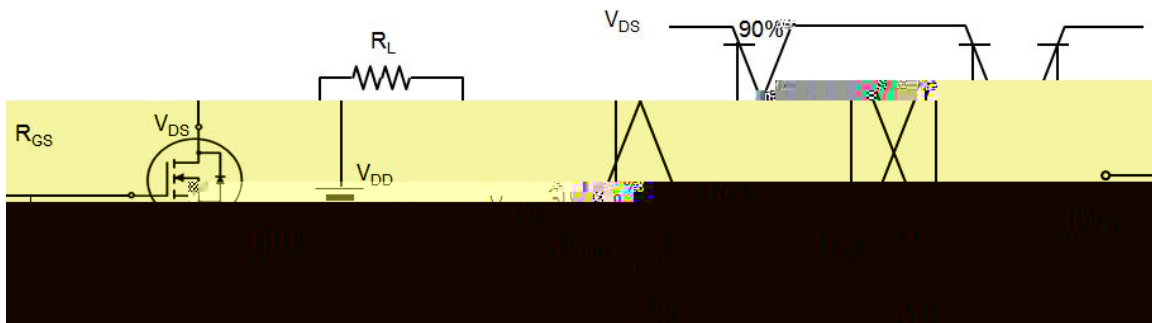
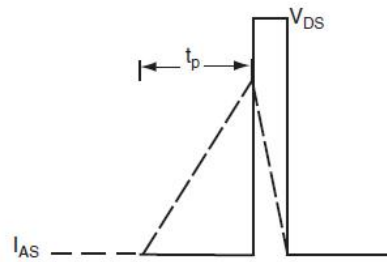

0 0 1

(

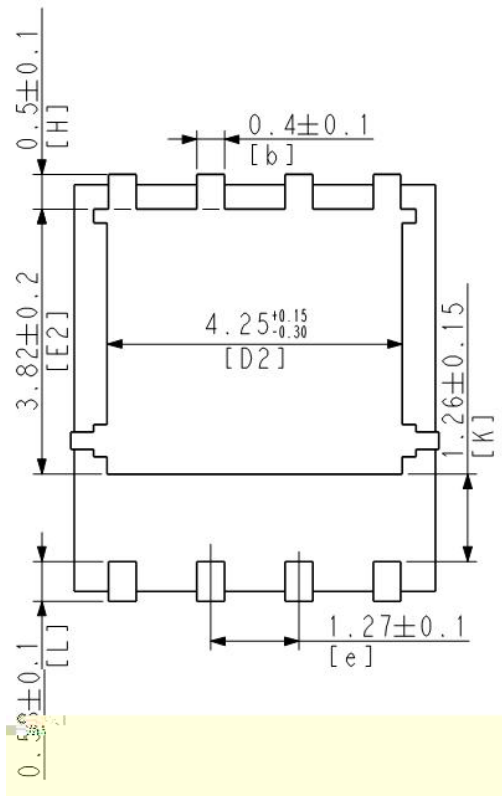
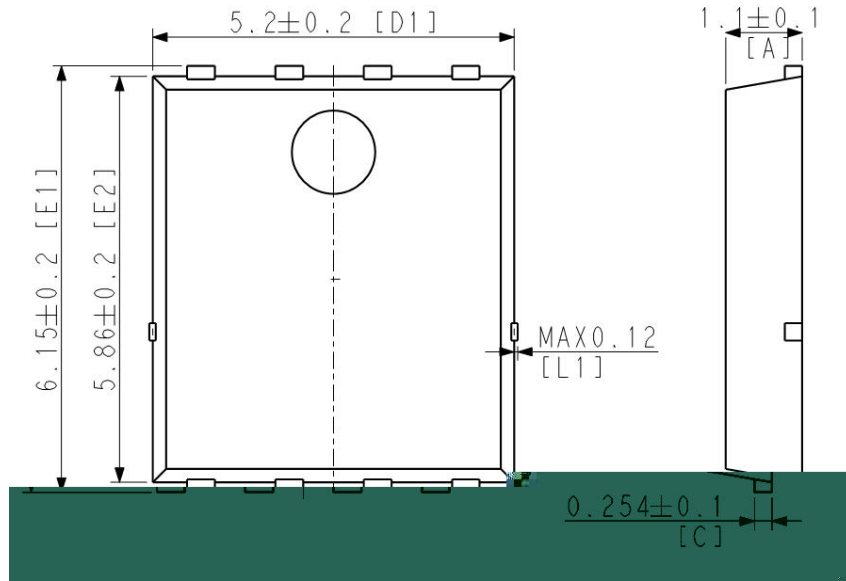

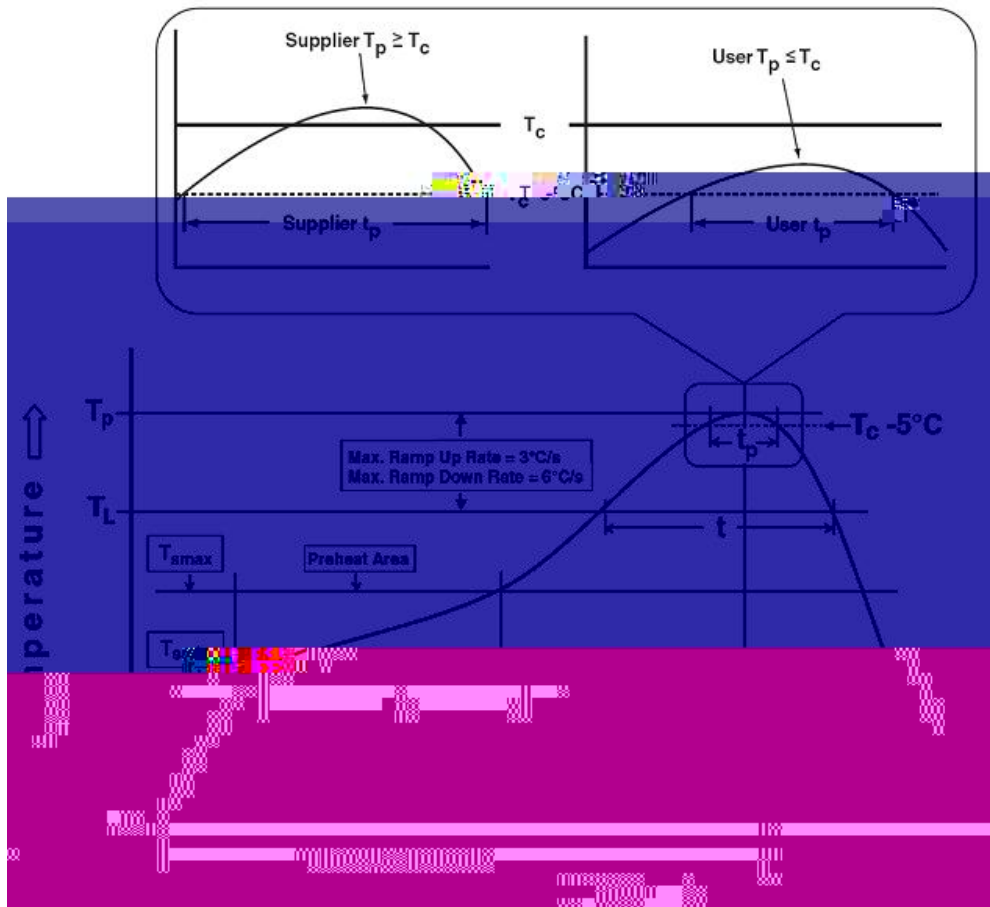

	-	-
&		



