

%) Ω



--	--	--	--	--

0%

0%

		0	0%			
		0	0			
			0 %			(
		0	0%			
		0±	% 0			
		0	0)		%,) (
		0'	(0'		,	% (
		0	0		*	
		0)	0		%	

0%

		0	0			
		0	0			
		0	0%			
			0			

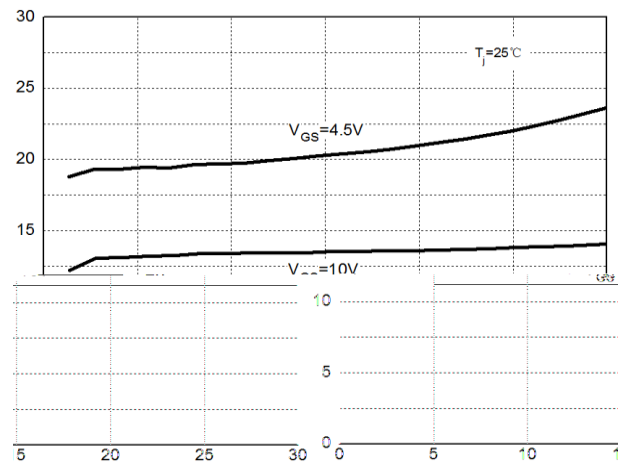
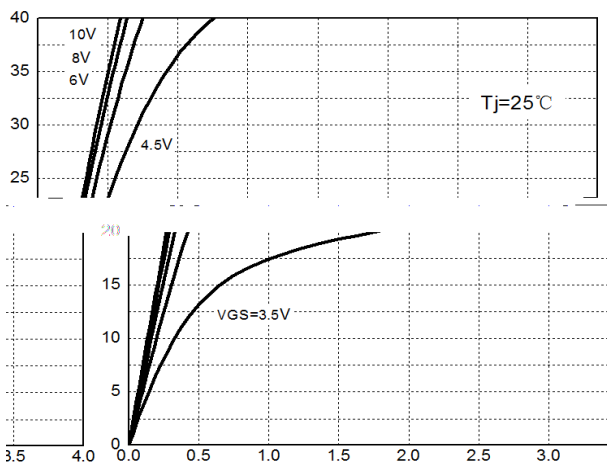
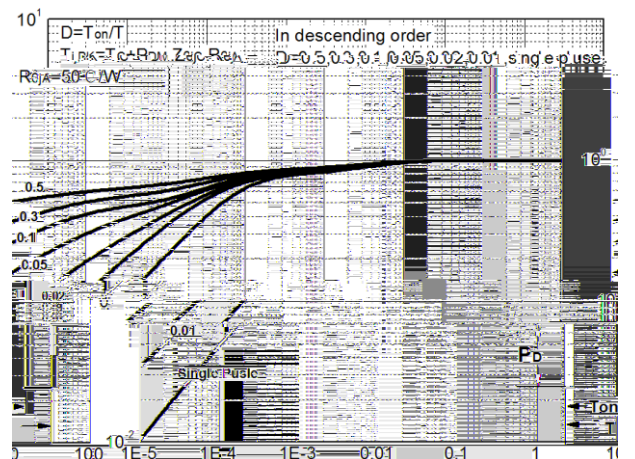
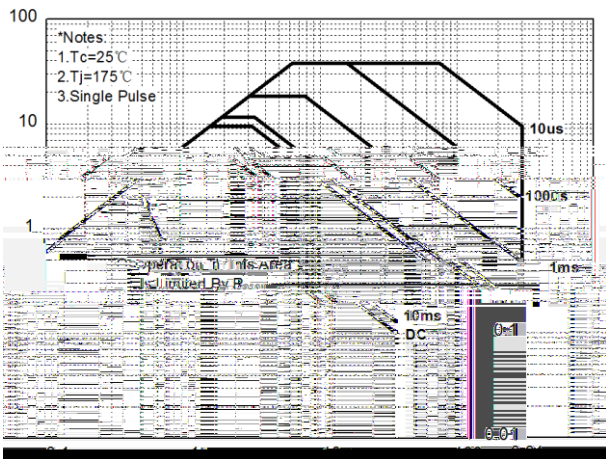
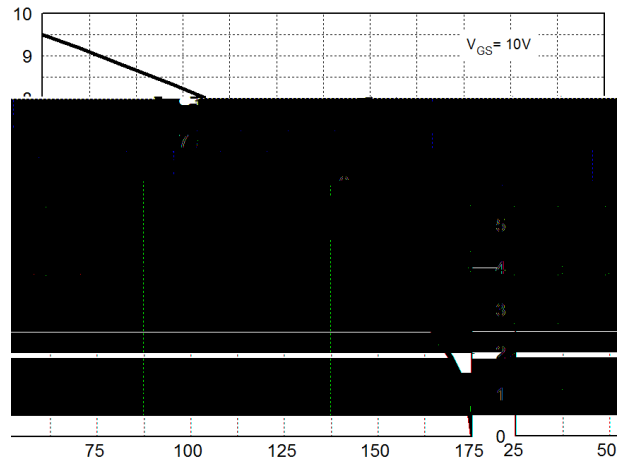
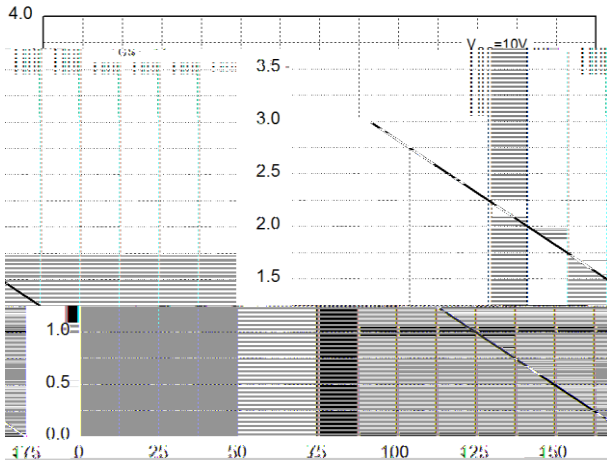

nC

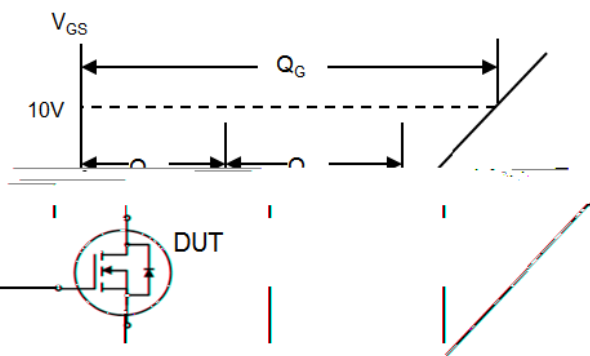
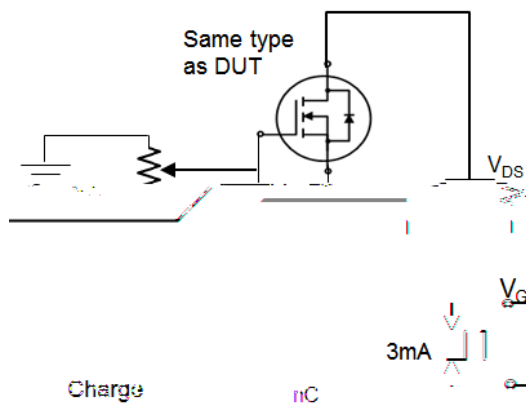
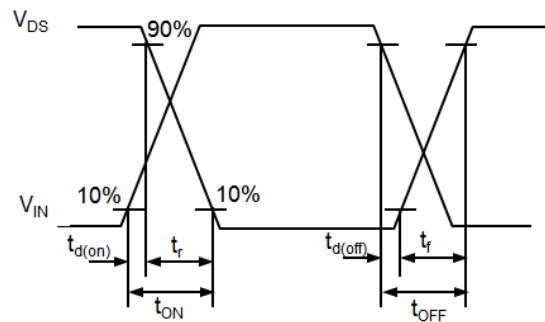
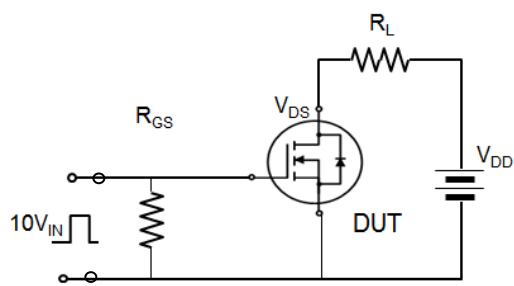
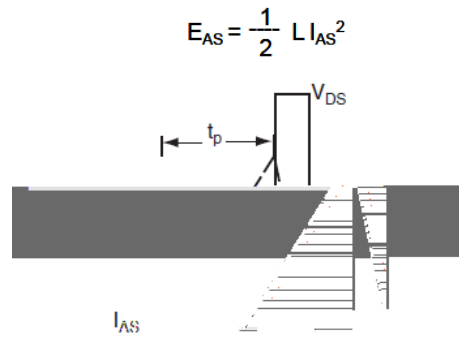
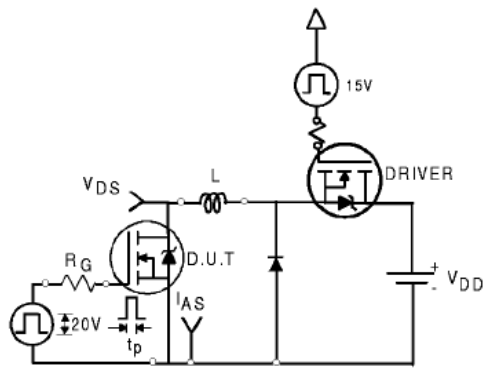

0%

		0	0 %		
		0	0		
			0 %		(
		0	0 %		,
		0 ± %	0		
		0	0)		%)
		0 ' (0 ' (' ((
		0	0		*
		0	0		%
		0	0		%

0%

		0	0		(
		0	0		%
		0 %			%
			0)
		0	0'		(
		0)	0		(
		0			(
	0				%
	0 ' (0 %			%
		0)			(')
					%

- %

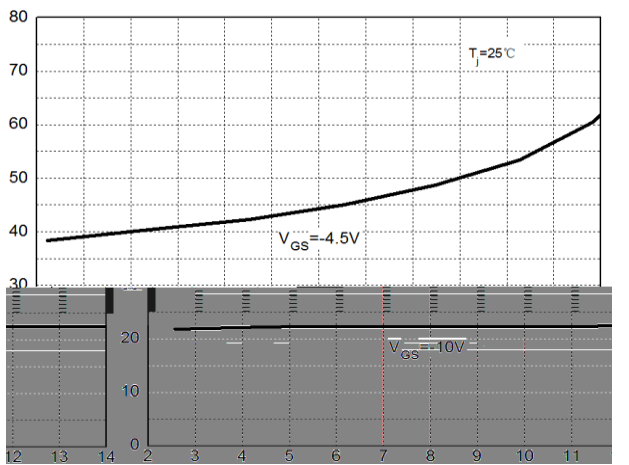
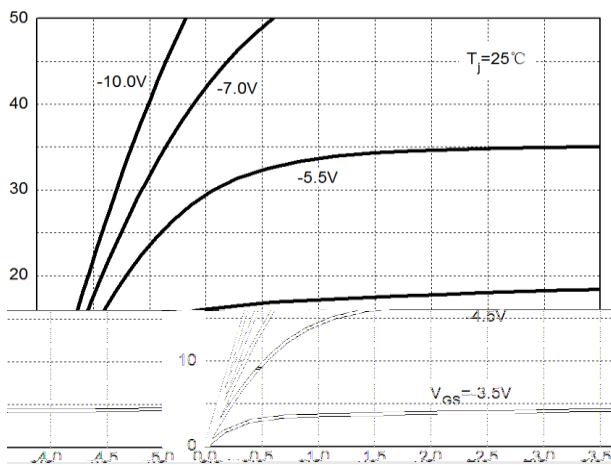
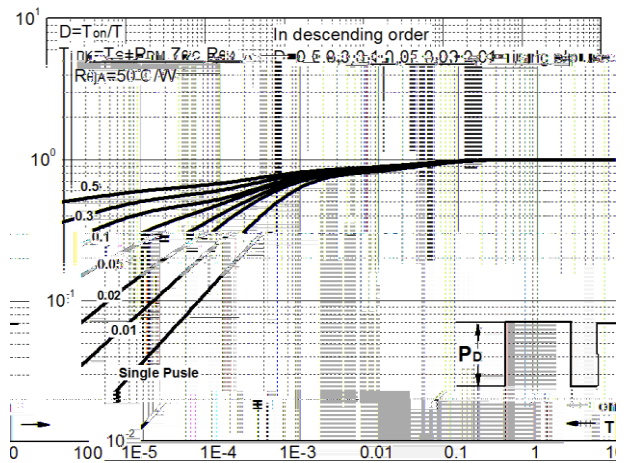
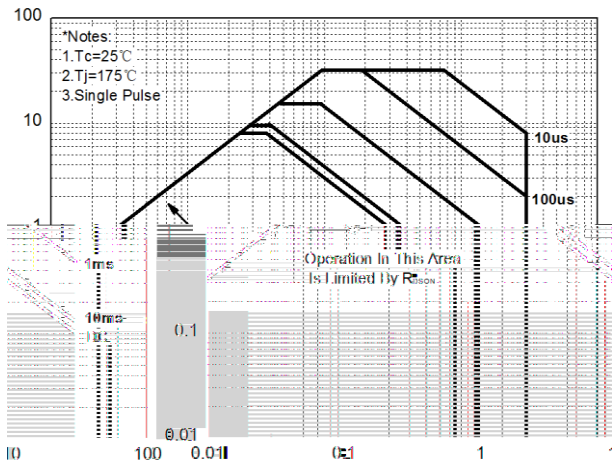
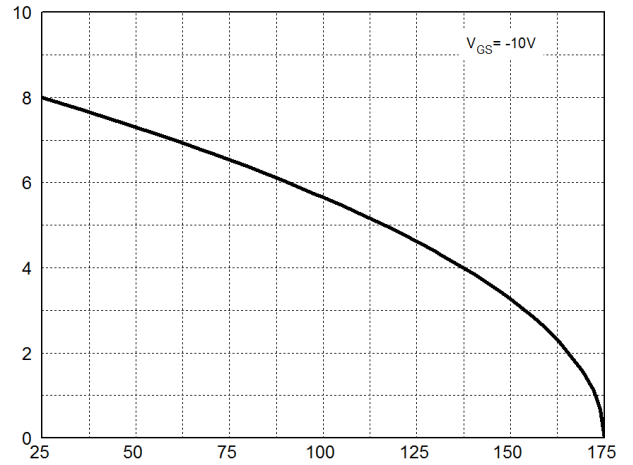
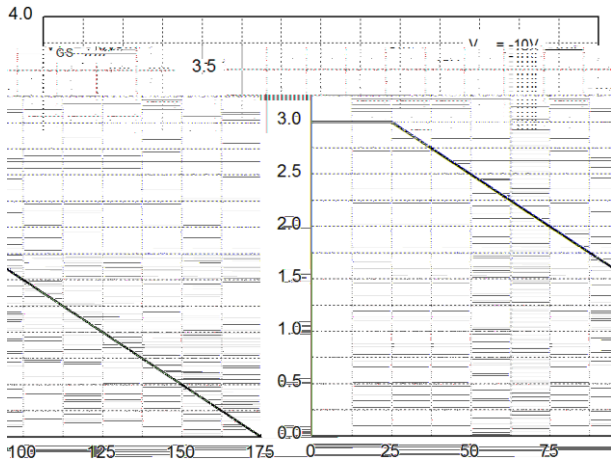

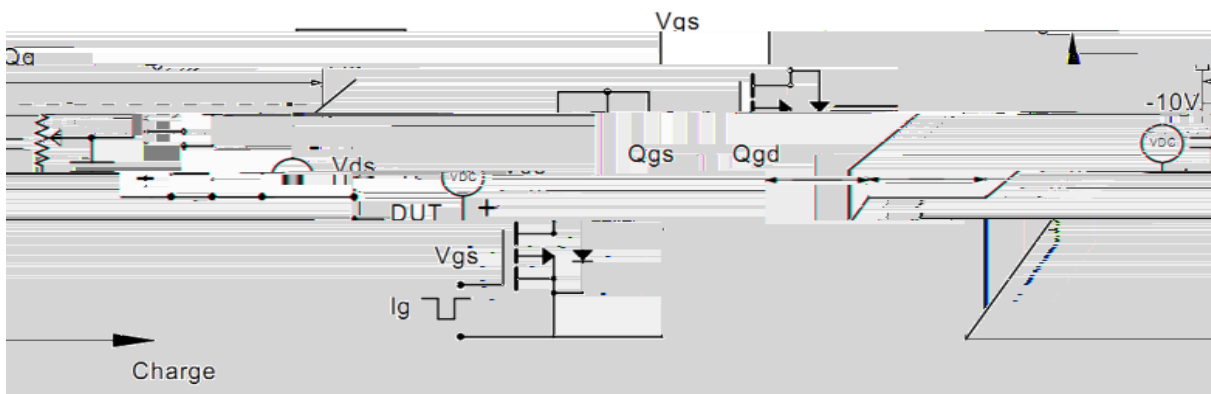
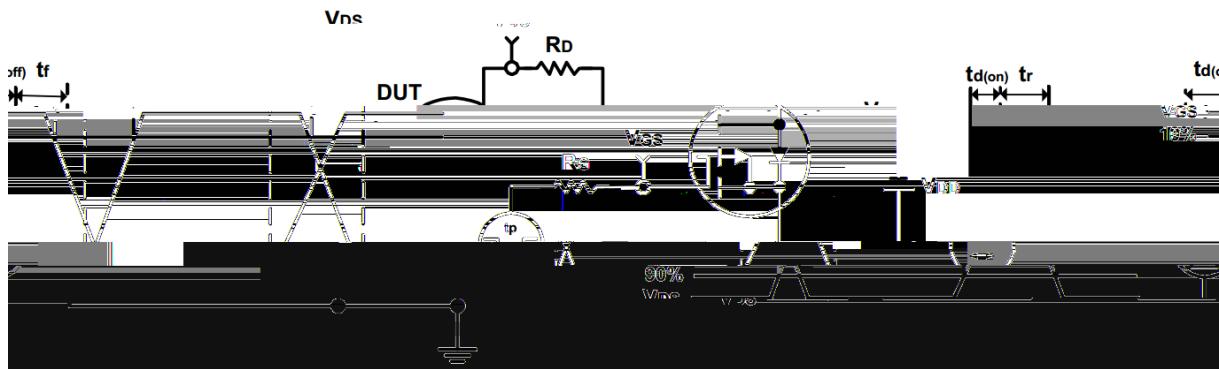
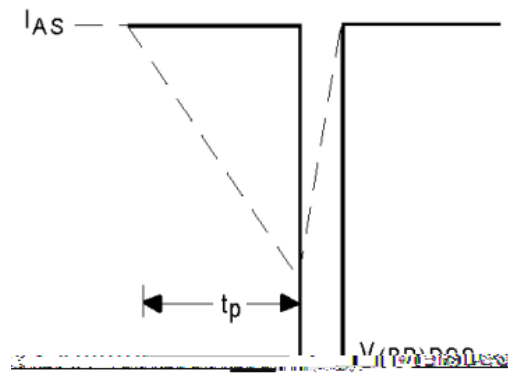
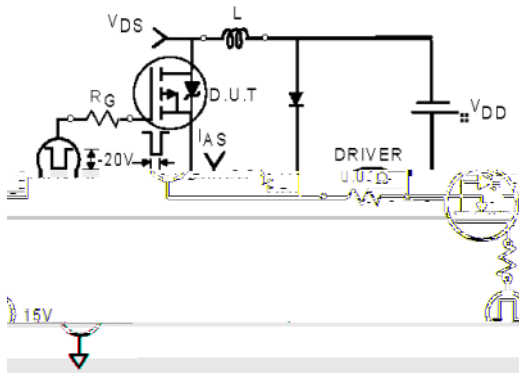

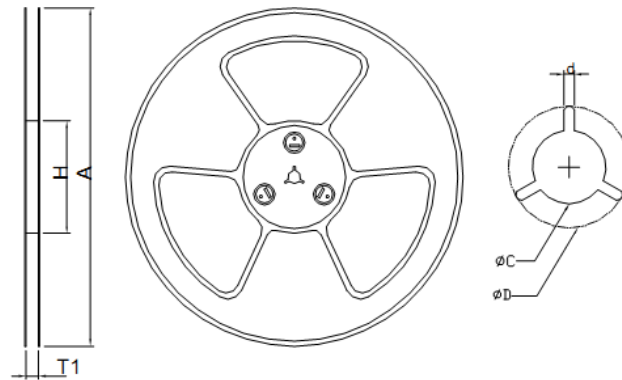
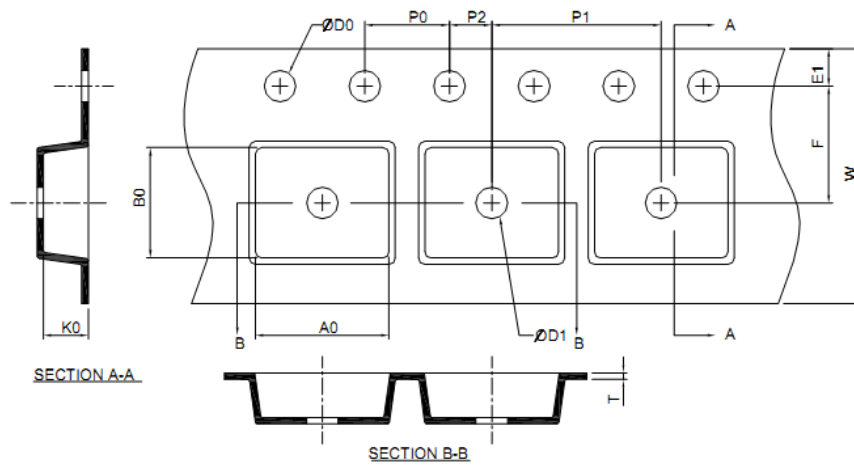

Application	A	H	T1	C	d	D	W	E1	F
SOP8L	3.0 ±0.10	1.5 ^{+0.10} _{-0.00}	1.5 MIN.	0.6 ^{+0.00} _{-0.40}	6.40 ±0.20	5.20 ±0.20	2.10 ±0.20	4.0 ±0.10	8.0 ±0.10

(mm)

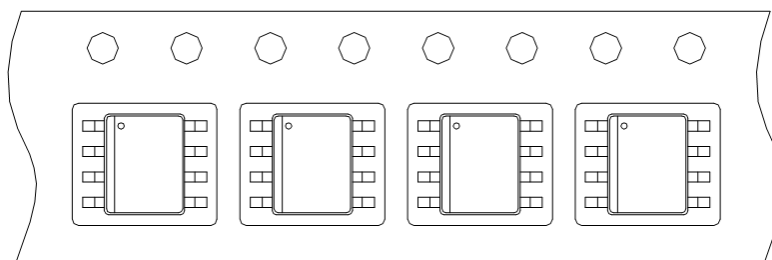
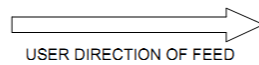

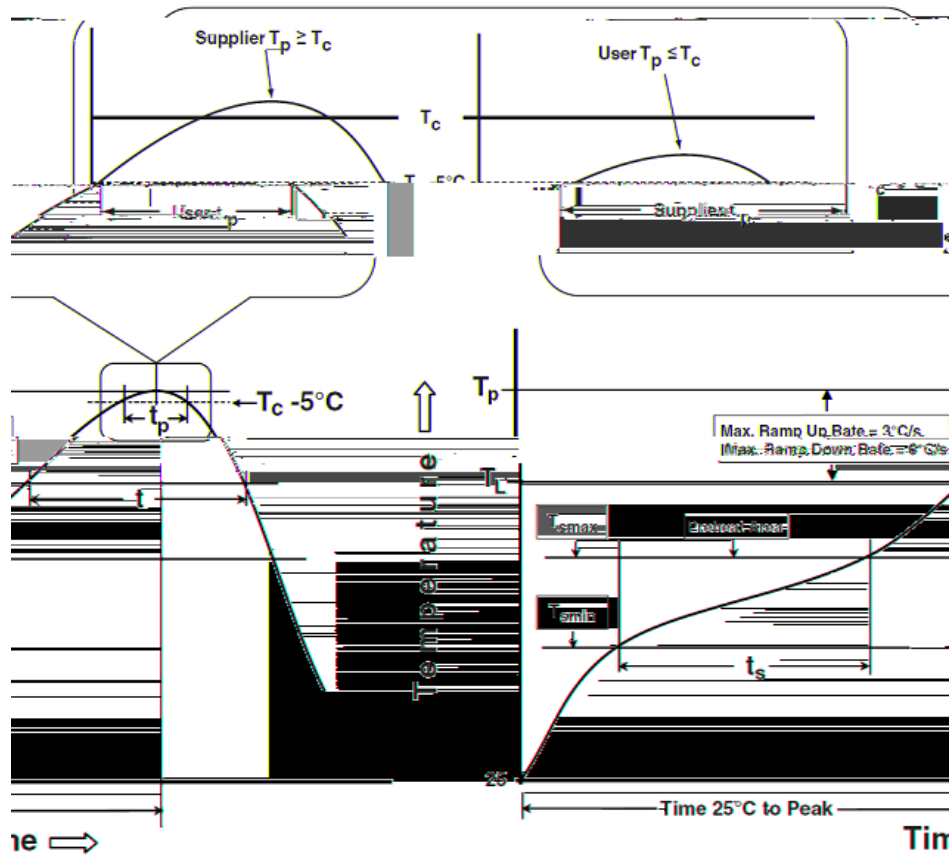

	(%)	(%)
	(%)	(% *
		%
(%	
))
%)	

	3	3
%(% (%%
%(%%	%%

%

	3	3	3
/)	%)	%)	%)
) %(%)	%)	% (
%(%)	% (% (

	%% %	(% (
	%%) (%
	%% %	,) % %
	%% ')	(((

-

-

, %

-) %)) (*)

-) %)) (* (

-

-