

N-Channel Enhancement Mode MOSFET

Features

- 68V / 120 A
 $R_{DS(ON)} = 5.0\text{ m}\ (\text{typ.}) @ V_{GS} = 10\text{V}$
- Avalanche Rated
- Reliable and Rugged
- Lead Free and Green Devices Available (RoHS Compliant)

Pin Description

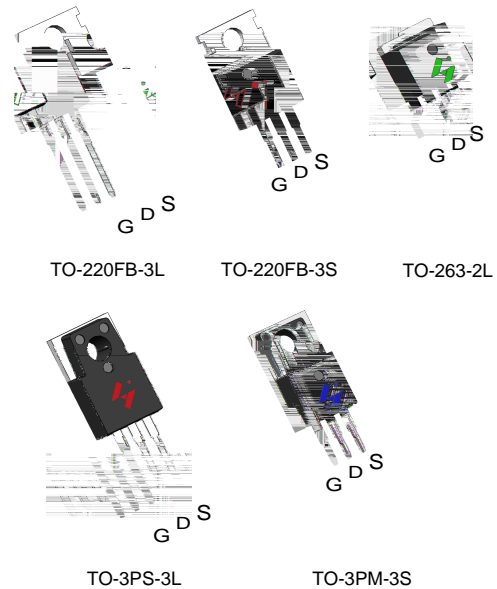



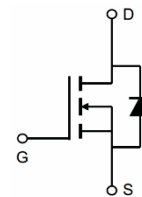

Applications

Power Management for Inverter Systems.



N-Channel MOSFET

Ordering and Marking Information

 P HY3007 XYMXXXXXX	 M HY3007 XYMXXXXXX	 B HY3007 XYMXXXXXX	Package Code P : TO-220FB-3L M : TO-220FB-3M B: TO-263-2L PS: TO-3PS-3L PM: TO-3PM-3S
 PS HY3007 XYMXXXXXX	 PM HY3007 XYMXXXXXX	Date Code XYMXXXXXX	

Note: HUAYI lead-free products contain molding compounds/die attach materials and 100% matte tin plate Termination finish; which are fully compliant with RoHS. HUAYI lead-free products meet or exceed the lead-free requirements of IPC/JEDEC J-STD-020 for MSL classification at lead-free peak reflow temperature. HUAYI defines "Green" to mean lead-free (RoHS compliant) and halogen free (Br or Cl does not exceed 900ppm by weight in homogeneous material and total of Br and Cl does not exceed 1500ppm by weight).

HUAYI reserves the right to make changes, corrections, enhancements, modifications, and improvements to this product and/or to this document at any time without notice.

Absolute Maximum Ratings

Symbol	Parameter	Rating	Unit
Common Ratings ($T_C=25^\circ\text{C}$ Unless Otherwise Noted)			
V_{DSS}	Drain-Source Voltage	68	V
V_{GSS}	Gate-Source Voltage	± 25	
T_J	Maximum Junction Temperature	175	$^\circ\text{C}$
T_{STG}	Storage Temperature Range	-55 to 175	$^\circ\text{C}$
I_S	Diode Continuous Forward Current	$T_C=25^\circ\text{C}$ 120	A
Mounted on Large Heat Sink			
I_{DM}		$T_C=25^\circ\text{C}$ 420**	A
I_D	Continuous Drain Current	$T_C=25^\circ\text{C}$ 120	A
		$T_C=100^\circ\text{C}$ 82	
P_D	Maximum Power Dissipation	$T_C=25^\circ\text{C}$ 200	W
		$T_C=100^\circ\text{C}$ 100	
R_{JC}	Thermal Resistance-Junction to Case	0.75	$^\circ\text{C/W}$
R_{JA}	Thermal Resistance-Junction to Ambient	62.5	
Avalanche Ratings			
E_{AS}	Avalanche Energy, Single Pulsed	$L=0.5\text{mH}$ 510***	mJ

Electrical Characteristics ($T_C = 25^\circ\text{C}$ Unless Otherwise Noted)

Symbol	Parameter	Test Conditions	HY3007			Unit
			Min.	Typ.	Max.	
Static Characteristics						
BV				68		

Electrical Characteristics (Cont.) ($T_C = 25\text{ C}$ Unless Otherwise Noted)

Symbol	Parameter	Test Conditions	HY3007			Unit
			Min.	Typ.	Max.	
Dynamic Characteristics						
R_G	Gate Resistance	$V_{GS}=0V, V_{DS}=0V, F=1MHz$	-	2.6	-	
C_{iss}	Input Capacitance	$V_{GS}=0V,$ $V_{DS}=25V,$ Frequency=1.0MHz	-	3050	-	pF
C_{oss}	Output Capacitance		-	920	-	
C_{rss}	Reverse Transfer Capacitance		-	455	-	
$t_{d(ON)}$	Turn-on Delay Time	$V_{DD}=34V, R_G = 5\ \Omega,$ $I_{DS}=60A, V_{GS}=10V,$	-	20	42	ns
T_r	Turn-on Rise Time		-	11	23	
$t_{d(OFF)}$	Turn-off Delay Time		-	73	140	
T_f	Turn-off Fall Time		-	63	125	
Gate Charge Characteristics^b						
Q_g	Total Gate Charge	$V_{DS}=55V, V_{GS}=10V,$ $I_{DS}=60A$	-	76	112	nC
Q_{gs}	Gate-Source Charge		-	13	-	
Q_{gd}	Gate-Drain Charge		-	30	-	

Note * : Pulse test ; pulse width 300 μ s, duty cycle 2%.

Typical Operating Characteristics (Cont.)

Drain-Source On Resistance

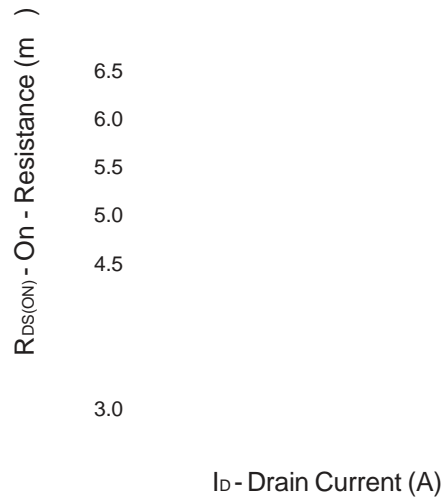

Drain-Source On Resistance

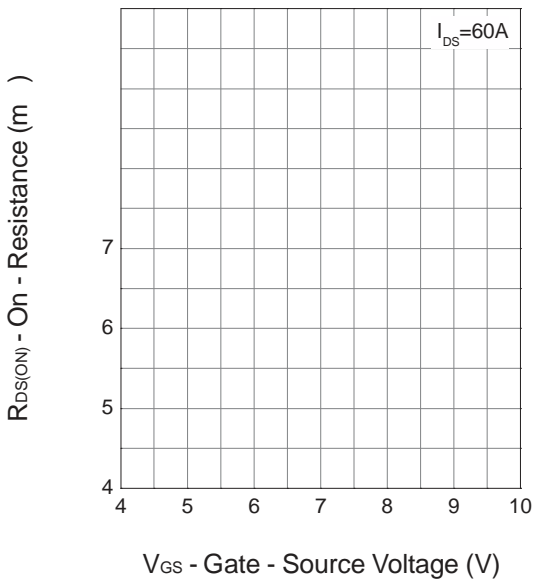

Gate Threshold Voltage

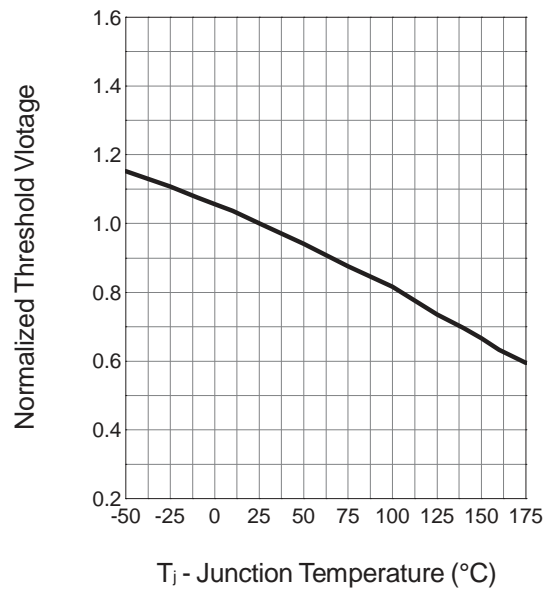

Typical Operating Characteristics (Cont.)

Drain-Source On Resistance

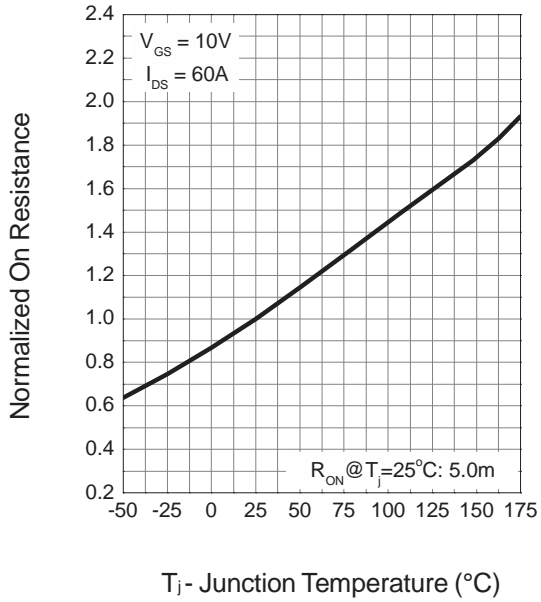

Source-Drain Diode Forward

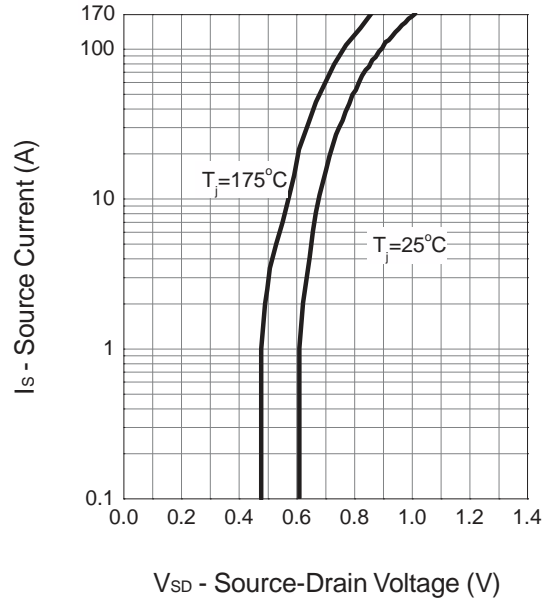

Avalanche Test Circuit

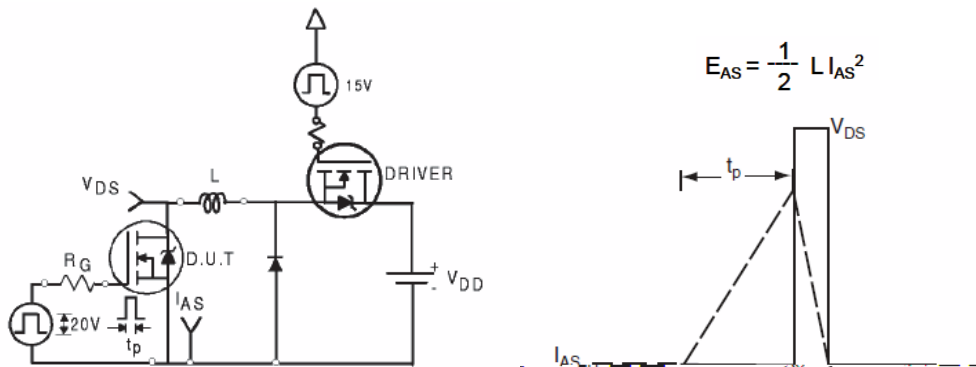

Switching Time Test Circuit

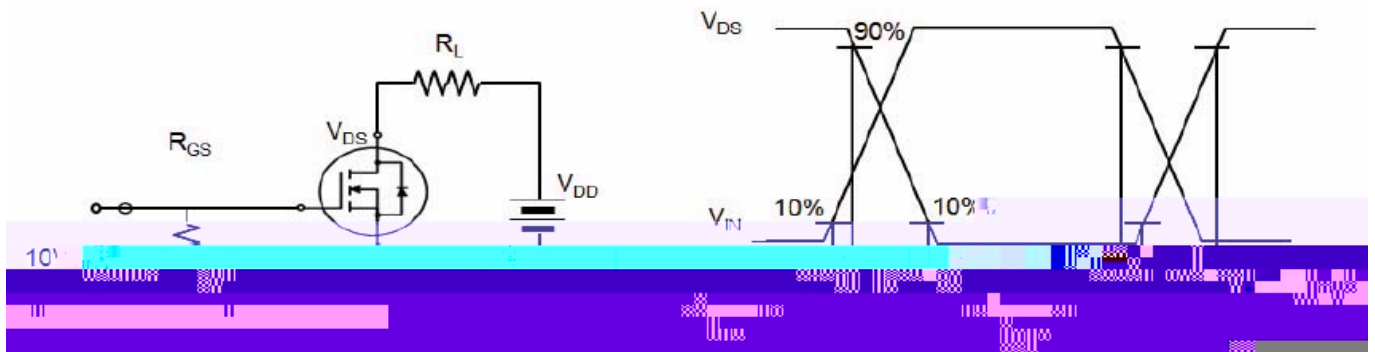

Gate Charge Test Circuit

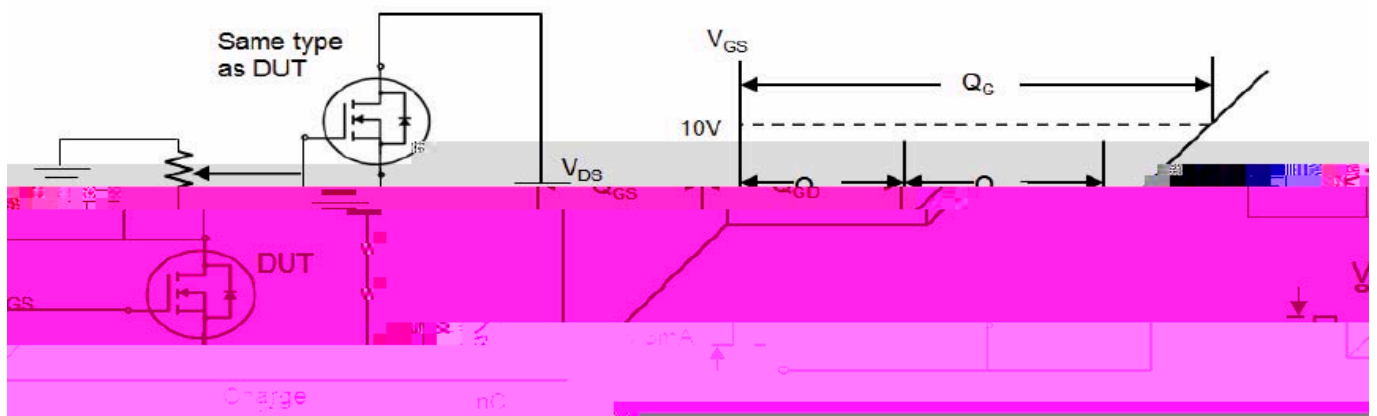

Device Per Unit

Package Type	Unit	Quantity
TO-220FB-3L	Tube	50

Package Information

TO-220FB-3L

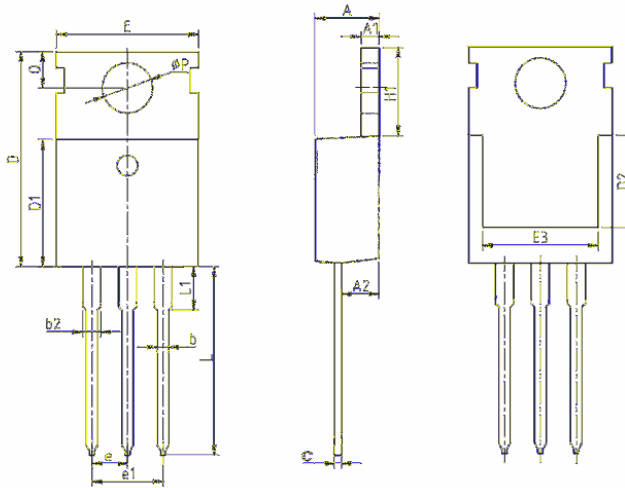

COMMON DIMENSIONS

SYMBOL	mm		
	MIN	NOM	MAX
A	4.37	4.57	4.77
A1	1.25	1.30	1.45
A2	2.20	2.40	2.60
b	0.70	0.80	0.95
b2	1.17	1.27	1.47
c	0.40	0.50	0.65
D	15.10	15.60	16.10
D1	8.80	9.10	9.40
D2	5.50	-	-
E	9.70	10.00	10.30
E3	7.00	-	-
e	2.54 BSC		
e1	5.08 BSC		
H1	6.25	6.50	6.85
L	12.75	13.50	13.80
L1	-	3.10	3.40
P	3.40	3.60	3.80
Q	2.60	2.80	3.00

HY3007P/M/B/PS/PM

Device Per Unit

Package Type	Unit	Quantity
--------------	------	----------

Device Per Unit

Package Type	Unit	Quantity
TO-263-2L	Reel	50

Package Information

TO-263-2L

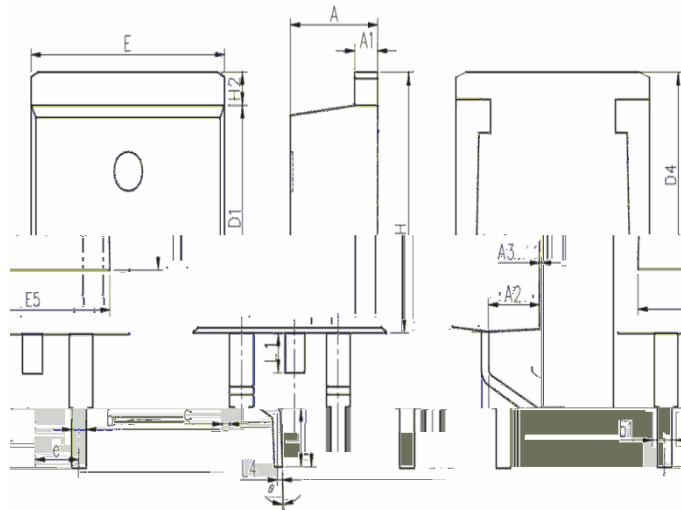

COMMON DIMENSIONS

SYMBOL	mm		
	MIN	NOM	MAX
A	4.37	4.57	4.77
A1	1.22	1.27	1.42
A2	2.49	2.69	2.89
A3	0	0.13	0.25
b	0.7	0.81	0.96
b1	1.17	1.27	1.47
c	0.3	0.38	0.53
D1	8.5	8.7	8.9
D4	6.6	-	-
E	9.86	10.16	10.36
E5	7.06	-	-
e	2.54 BSC		
H	14.7	15.1	15.5
H2	1.07	1.27	1.47
L	2	2.3	2.6
L1	1.4	1.55	1.7
L4	0.25 BSC		
	0°	5°	9°

Device Per Unit

Package Type	Unit	Quantity
TO-3PS-3L	Tube	50

Package Information

TO-3PS-3L

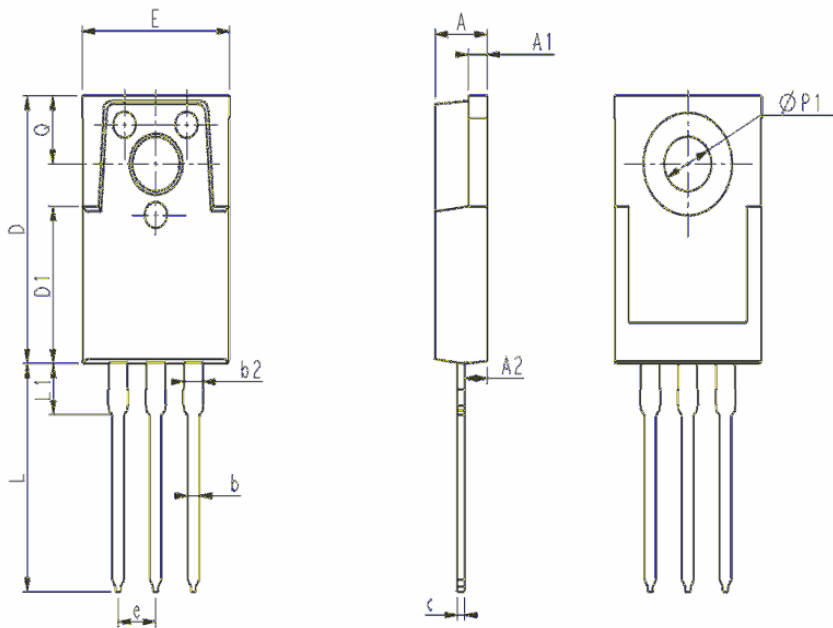

COMMON DIMENSIONS

SYMBOL	mm		
	MIN	NOM	MAX
A	3.36	3.56	3.76
A1	1.25	1.30	1.40
A2	1.39	1.54	1.69
b	0.75	0.80	0.90
b2	1.17	1.27	1.42
c	0.45	0.50	0.60
D	15.45	15.70	15.95
D1	9.00	9.20	9.40
E	9.88	10.00	10.20
e	2.54 BSC		
L	13.20	13.40	13.60
L1	-	3.00	3.30
P1	3.20 REF		
Q	3.88	4.00	4.12

Device Per Unit

Package Type	Unit	Quantity
TO-3PM-3S	Tube	50

Package Information

TO-3PM-3S

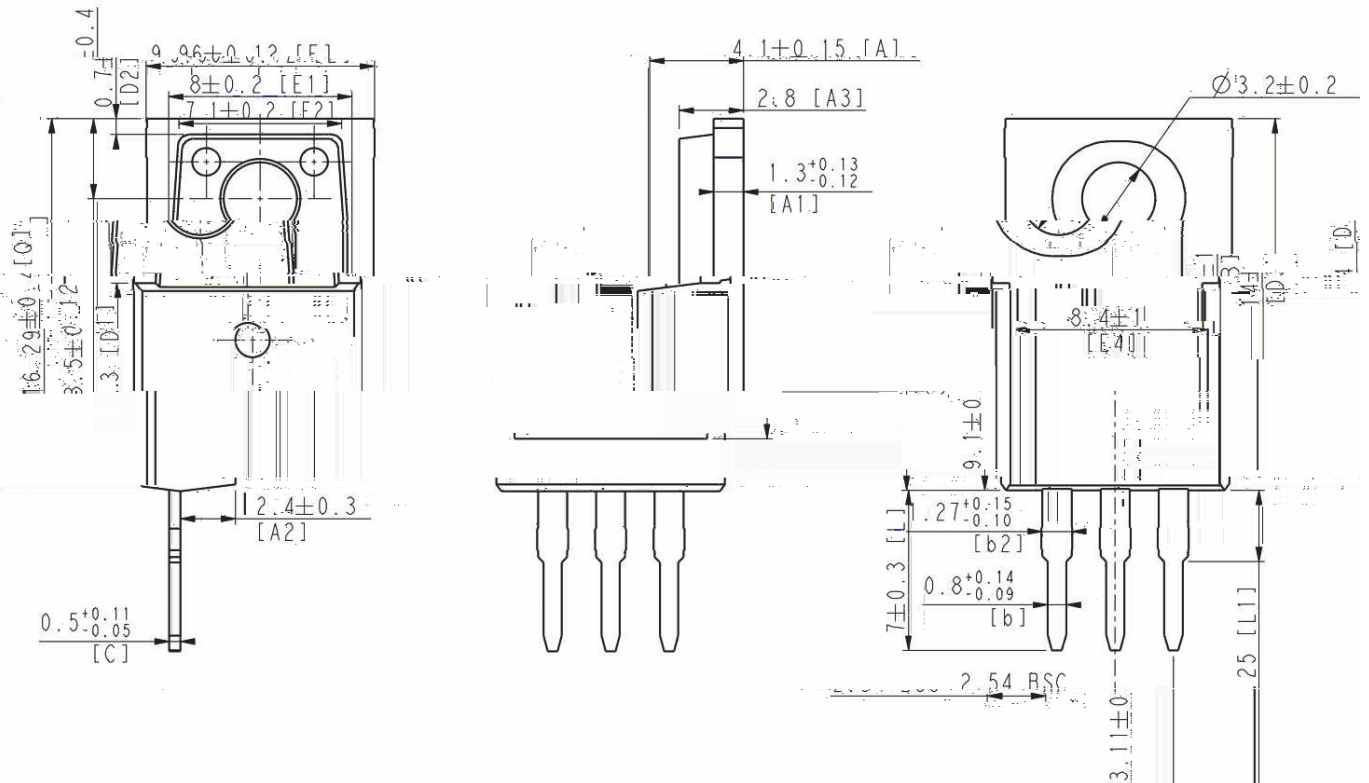

Classification Profile

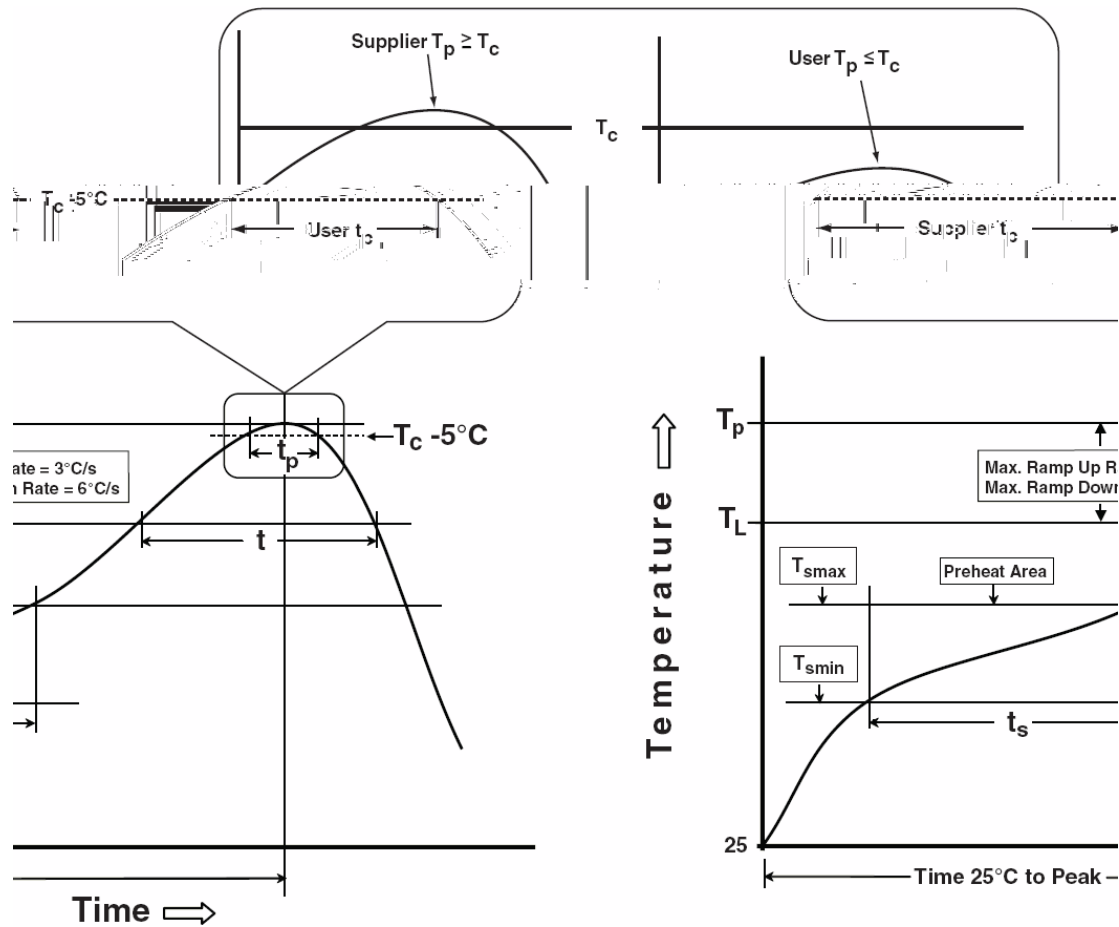

Classification Reflow Profiles

Profile Feature	Sn-Pb Eutectic Assembly	Pb-Free Assembly
Preheat & Soak		
Temperature min (T_{smin})	100 C	150 C
Temperature max (T_{smax})	150 C	200 C
Time (T_{smin} to T_{smax}) (t_s)	60-120 seconds	60-120 seconds
Average ramp-up rate (T_{smax} to T_p)	3 C/second max.	3 C/second max.
Liquidous temperature (T_L)	183 C	217 C
Time at liquidous (t_L)	60-150 seconds	60-150 seconds
Peak package body Temperature (T_p)*	See Classification Temp in table 1	See Classification Temp in table 2
Time (t_p)** within 5 C of the specified classification temperature (T_c)	20** seconds	30** seconds
Average ramp-down rate (T_p to T_{smax})	6 C/second max.	6 C/second max.
Time 25 C to peak temperature	6 minutes max.	8 minutes max.
* Tolerance for peak profile Temperature (T_p) is defined as a supplier minimum and a user maximum. ** Tolerance for time at peak profile temperature (t_p) is defined as a supplier minimum and a user maximum.		

